Service Guide

Part Number: E3632-90010
April 2000.

For Warranty information, refer to the back of the manual.

© Copyright Agilent Technologies, Inc. 2000
All Rights Reserved.

Agilent E3632A DC Power Supply

The Agilent E3632A is a high performance 120 watt-dual range DC power supply with GPIB and RS-232 interfaces. The combination of bench-top and system features in this power supply provides versatile solutions for your design and test requirements.

Convenient bench-top features

- Dual range
- Easy-to-use knob control settings
- Highly visible vacuum-fluorescent display meters
- High accuracy and high resolution
- Remote voltage sensing
- Overvoltage and overcurrent protection
- Output on/off
- Excellent load and line regulation and low ripple and noise
- Operating states storage
- Portable, ruggedized case with non-skid feet

Flexible system features

- GPIB (IEEE-488) and RS-232 interfaces are standard
- SCPI (Standard Commands for Programmable Instruments) compatibility
- I/O setup easily done from front-panel
- Software calibration, no internal adjustments required

Agilent E3632A DC Power Supply

The Front Panel at a Glance

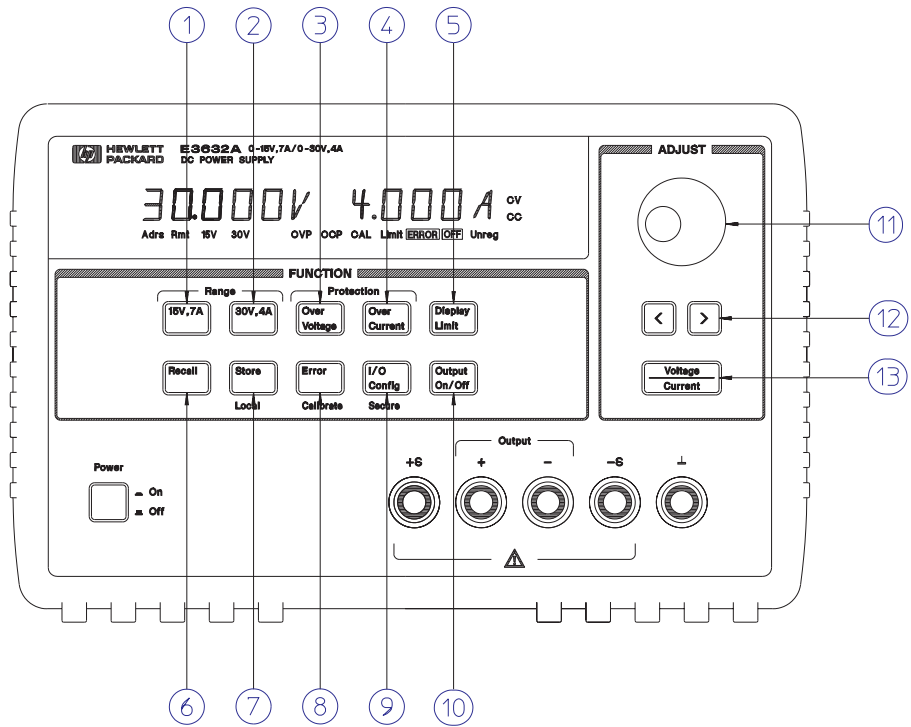

- | | |
|-------------------------------------|---|
| 1 15V/7A range selection key | 8 Error / Calibrate key |
| 2 30V/4A range selection key | 9 I/O Configuration / Secure key |
| 3 Overvoltage protection key | 10 Output On/Off key |
| 4 Overcurrent protection key | 11 Control knob |
| 5 Display limit key | 12 Resolution selection keys |
| 6 Recall operating state key | 13 Voltage/current adjust selection key |
| 7 Store operating state / Local key | |

- 1 **15V/7A range selection key** Selects the 15V/7A range and allows the full rated output to 15V7A.
- 2 **30V/4A range selection key** Selects the 30V/4A range and allows the full rated output to 30V/4A.
- 3 **Overvoltage protection key** Enables or disables the overvoltage protection function, sets trip voltage level, and clears the overvoltage condition.
- 4 **Overcurrent protection key** Enables or disables the overcurrent protection function, sets trip current level, and clears the overcurrent condition.
- 5 **Display limit key** Shows voltage and current limit values on the display and allows knob adjustment for setting limit values.
- 6 **Recall operating state key** Recalls a previously stored operating state from location "1", "2", or "3".
- 7 **Store operating state / Local key**¹ Stores an operating state in location "1", "2", or "3" / or returns the power supply to local mode from remote interface mode.
- 8 **Error / Calibrate key**² Displays error codes generated during operations, self-test and calibration / or enables calibration mode (the power supply must be *unsecured* before performing calibration).
- 9 **I/O Configuration / Secure key**³ Configures the power supply for remote interfaces / or secure or unsecure the power supply for calibration.
- 10 **Output On/Off key** Enables or disables the power supply outputs. This key toggles between on and off.
- 11 **Control knob** Increases or decreases the value of the blinking digit by turning clockwise or counter clockwise.
- 12 **Resolution selection keys** Move the blinking digit to the right or left.
- 13 **Voltage/current adjust selection key** Selects the knob control function for voltage or current adjustment.

¹*The key can be used as the "Local" key when the power supply is in the remote interface mode.*

²*You can enable the "calibration mode" by holding down this key when you turn on the power supply.*

³*You can use it as the "Secure" or "Unsecure" key when the power supply is in the calibration mode.*

Front-Panel Voltage and Current Limit Settings

You can set the voltage and current limit values from the front panel using the following method.

Use the voltage/current adjust selection key, the resolution selection keys, and the control knob to change the voltage and current limit value.

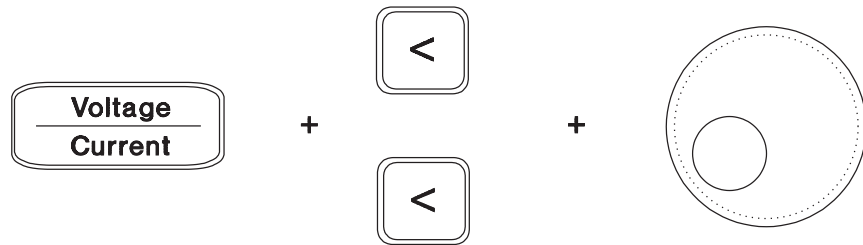

- 1 Select the desired range using the range selection keys after turning on the power supply.
- 2 Press the `Display Limit` key to show the limit values on the display.
- 3 Move the blinking digit to the appropriate position using the resolution selection keys and change the blinking digit value to the desired voltage limit by turning the control knob. If the display limit times out, press the `Display Limit` key again.
- 4 Set the knob to current control mode using the voltage/current adjust selection key.
- 5 Move the blinking digit to the appropriate position using the resolution selection keys and change the blinking digit value to the desired current limit by turning the control knob.
- 6 Press the `Output On/Off` key to enable the output. After about 5 seconds, the display will go to the output monitor mode automatically to display the voltage and current at the output or the display will go to the monitor mode immediately by pressing the `Output On/Off` key again.

Note

All front panel keys and controls can be disabled with remote interface commands. The Agilent E3632A must be in "Local" mode for the front panel keys and controls to function.

Display Annunciators

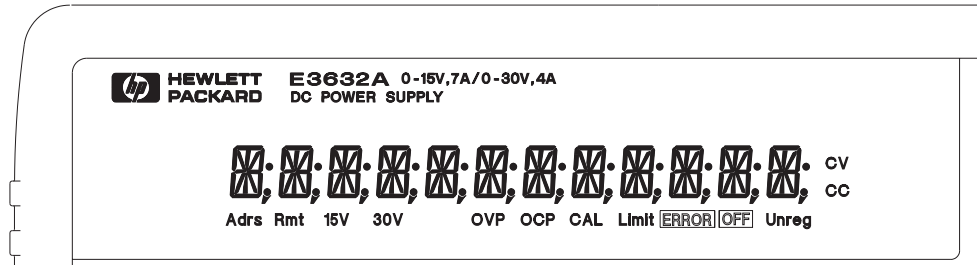

Adrs	Power supply is addressed to listen or talk over a remote interface.
Rmt	Power supply is in remote interface mode.
15V	Shows the 15V/7A range is selected.
30V	Shows the 30V/4A range is selected.
OVP	The overvoltage protection function is enabled when the annunciator turns on or the overvoltage protection circuit has caused the power supply to shutdown when the annunciator blinks.
OCP	The overcurrent protection function is enabled when the annunciator turns on or the overcurrent protection circuit has caused the power supply to shutdown when the annunciator blinks.
CAL	The power supply is in calibration mode.
Limit	The display shows the limit values of voltage and current.
ERROR	Hardware or remote interface command errors are detected and the error bit has not been cleared.
OFF	The output of the power supply is disabled.
Unreg	The output of the power supply is unregulated (output is neither CV nor CC).
CV	The output is in constant-voltage mode.
CC	The output is in constant-current mode.

To review the display annunciators, hold down **Display Limit** key as you turn on the power supply.

The Rear Panel at a Glance

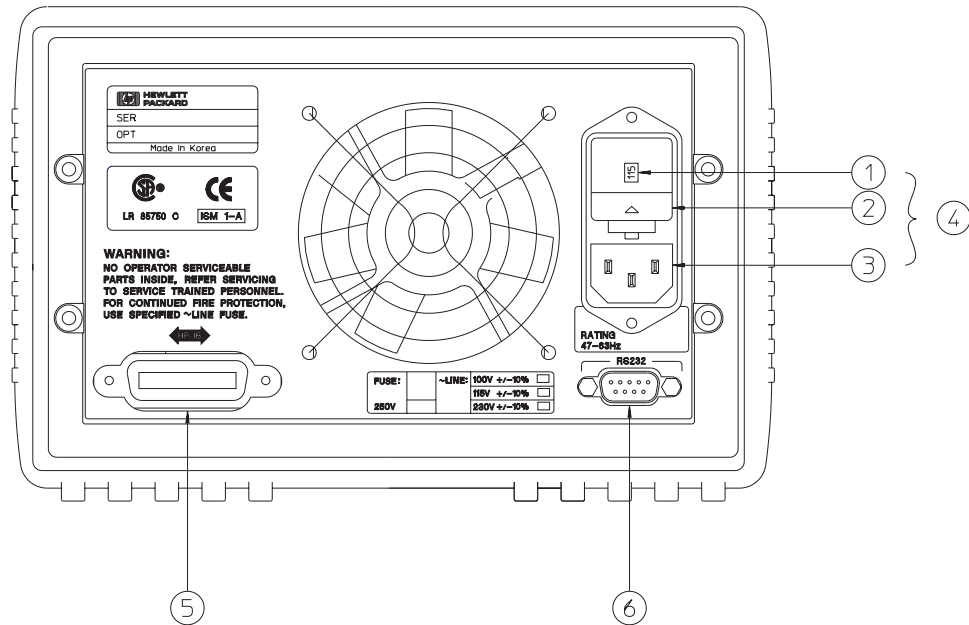

-
- | | |
|-----------------------------------|---------------------------------------|
| 1 Power-line voltage setting | 4 Power-line module |
| 2 Power-line fuse-holder assembly | 5 GPIB (IEEE-488) interface connector |
| 3 AC inlet | 6 RS-232 interface connector |

Use the front-panel `I/O Config` key to:

- Select the GPIB or RS-232 interface (see chapter 3 in User's Guide).
- Set the GPIB bus address (see chapter 3 in User's Guide).
- Set the RS-232 baud rate and parity (see chapter 3 in User's Guide).

In This Book

Specifications Chapter 1 lists the power supply's specifications and describes how to interpret these specifications.

Quick Start Chapter 2 prepares the power supply for use and helps you get familiar with the front-panel features.

Calibration Procedures Chapter 3 provides performance verification and calibration procedures.

Theory of Operation Chapter 4 describes block and circuit level theory related to the operation of the power supply.

Service Chapter 5 provides guidelines for returning your power supply to Agilent Technologies for servicing, or for servicing it yourself.

Replaceable Parts Chapter 6 contains a detailed parts list of the power supply.

Backdating Chapter 7 describes the difference between this manual and older issues of this manual.

Schematics Chapter 8 contains the power supply's schematics, disassembly drawings, and component locator drawings.

*If you have questions relating to the operation of the power supply, call **1-800-452-4844** in the United States, or contact your nearest Agilent Technologies Sales Office.*

If your Agilent E3632A fails within three years of purchase, Agilent will repair or replace it free of charge. Call 1-800-258-5165 ("Express Exchange") in the United States, or contact your nearest Agilent Technologies Sales Office.

Contents

Chapter 1 Specifications

- Performance Specifications 15
- Supplemental Characteristics 17

Chapter 2 Quick Start

- To Prepare the Power Supply for Use 23
- To Check the Rated Voltages of the Power Supply 25
- To Check the Rated Currents of the Power Supply 26
- To Use the Power Supply in Constant Voltage Mode 28
- To Use the Power Supply in Constant Current Mode 30
- To Store and Recall the Instrument State 32
- To Program Overvoltage Protection 34
 - Setting the OVP Level and Enable the OVP Circuit 34
 - Checking OVP Operation 35
 - Clearing the Overvoltage Condition 35
- To Program Overcurrent Protection 37
 - Setting the OCP Level and Enable the OCP Circuit 37
 - Checking OCP Operation 38
 - Clearing the Overcurrent Condition 38
- To Rack Mount the Power Supply 39

Chapter 3 Calibration Procedures

- Agilent Technologies Calibration Services 43
- Calibration Interval 43
- Automating Calibration Procedures 44
- Recommended Test Equipment 44
- Test Considerations 45
- Performance Verification Tests 46
 - Self-Test 46
 - Performance Verification Tests 46
- Measurement Techniques 47
 - Setup for Most Tests 47
 - Electronic Load 48
 - Current-Monitoring Resistor 48
 - Programming 48

Contents**Chapter 3 Calibration Procedures (continued)**

Constant Voltage (CV) Verifications	49
Constant Voltage Test Setup	49
Voltage Programming and Readback Accuracy	49
CV Load Regulation	50
CV Line Regulation	50
Normal Mode Voltage Noise (CV Ripple and Noise)	51
Load Transient Response Time	52
Constant Current (CC) Verifications	53
Constant Current Test Setup	53
Current Programming and Readback Accuracy	53
CC Load Regulation	54
CC Line Regulation	55
Normal Mode Current Noise (CC Ripple and Noise)	55
Common Mode Current Noise	56
Performance Test Record for Agilent Technologies E3632A	57
CV Performance Test Record	57
CC Performance Test Record	57
Calibration Security Code	58
To Unsecure the Power Supply for Calibration	59
To Unsecure the Power Supply Without the Security Code	60
Calibration Count	61
Calibration Message	61
General Calibration/Adjustment Procedure	62
Voltage and OVP Calibration	63
Current and OCP Calibration	65
Aborting a Calibration in Progress	68
Calibration Record for Agilent Technologies E3632A	69
Error Messages	70
Calibration Program	72

Chapter 4 Theory of Operation

Block Diagram Overview	79
AC Input and Bias Supplies	81
Floating Logic	82
D-to-A Converter	84
A-to-D Converter	85
Power Mesh and Control	86
Earth-Referenced Logic	88
Front Panel	88

Contents

Chapter 5 Service

Operating Checklist	91
Types of Service Available	92
Repacking for Shipment	93
Electrostatic Discharge (ESD) Precautions	94
Surface Mount Repair	94
To Replace the Power-Line Fuse	94
To Disconnect the Output Using an External Relay	95
Troubleshooting Hints	96
Self-Test Procedures	98

Chapter 6 Replaceable Parts

Replaceable Parts	102
To Order Replaceable Parts	102
Backdating and Part Changes	102
E3632-60002 Main PC Assembly	103
E3632-60004 Front-Panel Display PC Assembly	111
E3632-60005 Front Frame Assembly	112
E3632A Power Supply Assembly	112
Manufacturer's List	113

Chapter 7 Backdating

Chapter 8

Mechanical Disassembly	103
Component Locator	120
Power Circuit and Protection Circuit Schematic	121
Bias Supply Schematic	122
ADC and DAC System Schematic	123
Floating Logic Schematic	124
Earth-Referenced Logic Schematic	125
Display and Keyboard Schematic	126

Specifications

Specifications

The *performance* specifications are listed in the following pages. Specifications are warranted in the temperature range of 0 to 40°C with a resistive load. *Supplemental* characteristics, which are not warranted but are descriptions of performance determined either by design or testing. Chapter 3 "Calibration Procedures" contains procedures for verifying the performance specifications.

Performance Specifications

Output Ratings (@ 0°C - 40°C)

Low range	0 to +15 V/0 to 7 A
High range	0 to +30 V/0 to 4 A

Programming Accuracy^[1] 12 months (@ 25°C ± 5°C), ±(% of output + offset)

Voltage	0.05% + 10 mV
Current	0.2% + 10 mA

Readback Accuracy^[1] 12 months (over GPIB and RS-232 or front panel with respect to actual output @ 25°C ± 5°C), ±(% of output + offset)

Voltage	0.05% + 5 mV
Current	0.15 % + 5 mA

Ripple and Noise (with outputs ungrounded, or with either output terminal grounded, 20 Hz to 20 MHz)

Normal mode voltage	<0.35 mV rms and 2 mV p-p
Current	<2 mA rms
Common mode current	<1.5 μA rms

Load Regulation, ±(% of output + offset)

Change in output voltage or current for any load change within ratings with remote sensing connected.

Voltage	<0.01% + 2 mV
Current	<0.01% + 250 μA

Line Regulation, ±(% of output + offset)

Change in output voltage and current for any line change within ratings

Voltage	<0.01% + 2 mV
Current	<0.01% + 250 μA

^[1] Accuracy specifications are after an 1-hour warm-up with no load and calibration at 25°C

Chapter 1 Specifications

Performance Specifications

Programming Resolution

Voltage	1 mV
Current	0.5 mA

Readback Resolution

Voltage	0.5 mV
Current	0.1 mA

Front Panel Resolution

Voltage	1 mV
Current	1 mA

Transient Response Time

Less than 50 μ sec for output recover to within 15 mV following a change in output current from full load to half load or vice versa

Command Processing Time

Average time for output voltage to begin to change after receipt of digital data when the power supply is connected directly to the GPIB or RS-232 is less than 100 msec.

OVP and OCP Accuracy, (% of output + offset)

OVP	0.5% + 0.5 V
OCP	0.5% + 0.5 A

Activation time : Average time for output to start to drop after OVP or OCP condition occurs.

OVP	<1.5 msec when the trip voltage is equal or greater than 3 V
	<10 msec when the trip voltage is less than 3 V
OCP	<10 msec

Supplemental Characteristics

Output Programming Range (maximum programmable values)

Low range	0 to 15.45 V/0 to 7.21 A
High range	0 to 30.9 V/0 to 4.12 A
OVP	1 V to 32 V
OCP	0 A 7.5 A

Remote Sensing Capability

Voltage drop	Up to 1 V per each lead
Load regulation	Add 5 mV to spec for each 1-volt change in the + output lead due to load current changes.
Load voltage	Subtract voltage drop in load leads from specified output voltage at iing.

Temperature Coefficient, \pm (% of output + offset)

Maximum change in output/readback per °C after a 30-minute warm-up

Voltage	0.01% + 3 mV
Current	0.02% + 3 mA

Stability, \pm (% of output + offset)

Following a 1 hour warm-up, change in output over 8 hours under constant load, line, and ambient temperature

Voltage	0.02% + 1 mV
Current	0.1% + 1 mA

Voltage Programming Speed

Maximum time required for output voltage to settle within 1% of its total excursion (for resistive load). Excludes command processing time.

	<u>Full load</u>	<u>No load</u>
Up	50 msec	20 msec
Down	45 msec	400 msec

Chapter 1 Specifications

Supplemental Characteristics

Output Terminal Isolation (maximum, from chassis ground)

± 60 Vdc when connecting shorting conductors without insulation to the (+) output to the (+) sense and the (-) output and the (-) sense terminals.

± 240 Vdc when connecting insulated shorting conductors to the (+) output to the (+) sense and the (-) output and the (-) sense terminals.

AC Input Ratings (selectable via rear panel selector)

std	115 Vac \pm 10%, 47 to 63 Hz
opt 0E3	230 Vac \pm 10%, 47 to 63 Hz
opt 0E9	100 Vac \pm 10%, 47 to 63 Hz

Maximum Input Power

500 VA with full load

Cooling

Fan cooled

Operating Temperature

0 to 40°C for full rated output. At higher temperatures, the output current is derated linearly to 50% at 55°C maximum temperature.

Output Voltage Overshoot

During turn-on or turn-off of ac power, output plus overshoot will not exceed 1 V if the output control is set to less than 1 V. If the output control is set to 1 V or higher, there is no overshoot.

Programming Language

SCPI (Standard Commands for Programmable Instruments)

State Storage Memory

Three (3) user-configurable stored states

Recommended Calibration Interval

1 year

Dimensions*

213 mmW x 133 mmH x 348 mmD (8.4 x 5.2 x 13.7 in)

*See below for detailed information.

Weight

Net 9.5 kg (21 lb)

Shipping 12 kg (26 lb)

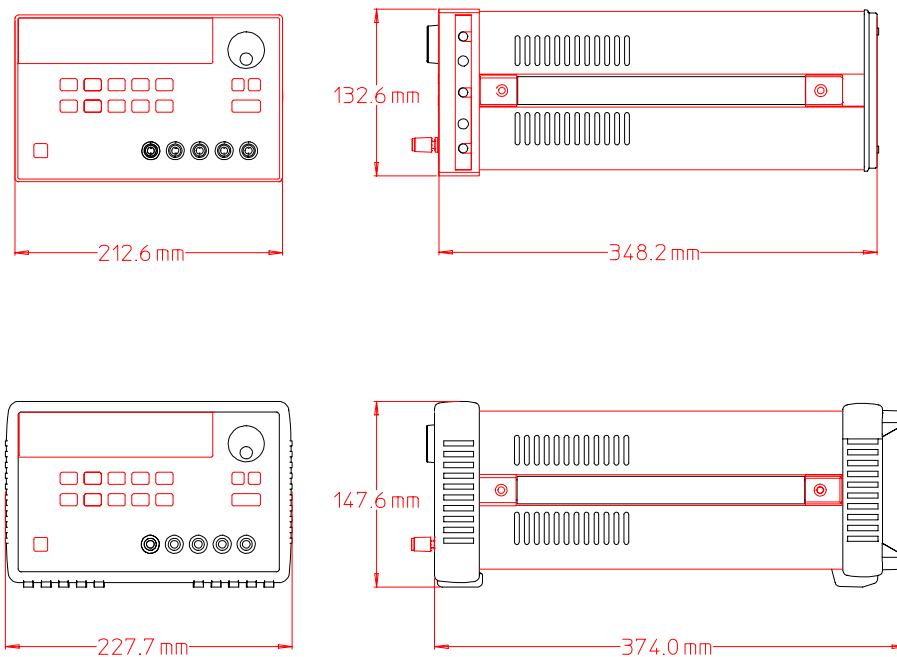

Figure 1-1. Dimensions of Agilent E3632A Power Supply

Quick Start

Quick Start

One of the first things you will want to do with your power supply is to become acquainted with its front panel. Written procedures in this chapter prepare the power supply for use and familiarize you with most front-panel operations.

- The power supply is shipped from the factory configured in the *front-panel* operation mode. At power-on, the power supply is automatically set to operate in the front-panel operation mode. When in this mode, the front-panel keys can be used. When the power supply is in *remote* operation mode, you can return to front-panel operation mode at any time by pressing the `Local` key if you did not previously send the front-panel lockout command. A change between front-panel and remote operation modes will *not* result in a change in the output parameters.
- The power supply has two output ranges of 15V/7A or 30V/4A. This feature allows more voltage at a lower current or more current at a lower voltage. The desired output range is selected from the front panel or over the remote interfaces. The **15V** or **30V** annunciator indicates the presently selected range.
- When you press the `Display Limit` key (the **Limit** annunciator blinks), the display of the power supply goes to the *limit* mode and the present limit values will be displayed. In this mode, you can also observe the change of the limit values when adjusting the knob. If you press the `Display Limit` key again or let the display time-out after several seconds, the power supply will return the display to the *meter* mode (the **Limit** annunciator turns off). In this mode, the actual output voltage and current will be displayed.
- The outputs of the power supply can be enabled or disabled from the front panel using the `Output On/Off` key. When the output is off, the **OFF** annunciator turns on and the output is disabled.
- The display provides the present operating status of the power supply with annunciators and also informs the user of error codes. For example, the power supply is operating in CV mode in the 15V/7A range and controlled from the front panel, then the **CV** and **+15V** annunciators will turn on. If, however, the power supply is remotely controlled, the **Rmt** annunciator will also turn on, and when the power supply is being addressed over GPIB interface, the **Adrs** annunciator will turn on. see “Display Annunciators”, on page 6 for more information.

To Prepare the Power Supply for Use

The following steps help you verify that the power supply is ready for use.

1 Check the list of supplied items.

Verify that you have received the following items with your power supply. If anything is missing, contact your nearest Agilent Technologies Sales Office.

- One appropriate power cord for your location.
- One *User's Guide*.
- This *Service Guide*.
- Certificate of Calibration.

2 Verify that the correct power-line voltage setting is selected and that the correct power-line fuse is installed.

The line voltage is set to 100, 115 or 230 Vac from the factory according to the input power option selected when you ordered the power supply. Change the voltage setting if it is not correct for your location (see the next page for detailed information). For 100 or 115 Vac operation, the correct fuse is 4 AT (Agilent part number 2110-0996) and for 230 Vac operation, the correct fuse is 2.5 AT (Agilent part number 2110-0999).

Power

3 Connect the power cord and turn on the power supply.

A *power-on self-test* occurs automatically when you turn on the power supply. The front-panel display will light up while the power supply performs its power-on self-test. After performing the self-test, the power supply will go into the *power-on / reset* state; all outputs are disabled (the **OFF** annunciator turns on); the 15V/7A range is selected (the **+15V** annunciator turns on); the knob is selected for *voltage* control. Notice that the **OVP** and **OCP** annunciators also turn on.

Output On/Off

4 Enable the outputs.

Press the `Output On/Off` key to enable the outputs. The **OFF** annunciator turns off and the **15V**, **OVP**, **OCP** and **CV** annunciators are lit. The *blinking* digit can be adjusted by turning the knob. Notice that the display is in the meter mode. "Meter mode" means that the display shows the actual output voltage and current.

Chapter 2 Quick Start
To Prepare the Power Supply for Use

1 Remove the power cord. Remove the fuse-holder assembly with a flat-blade screwdriver from the rear

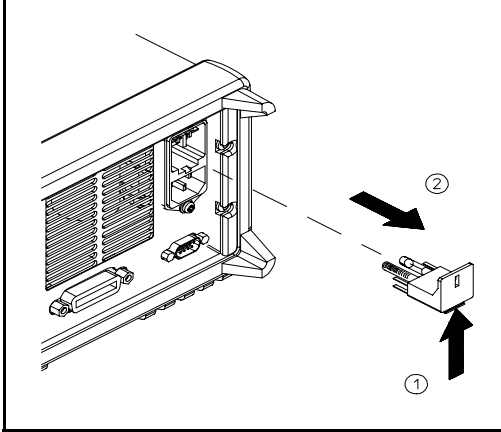

2 Install the correct line fuse. Remove the power-line voltage selector from the power-line module.

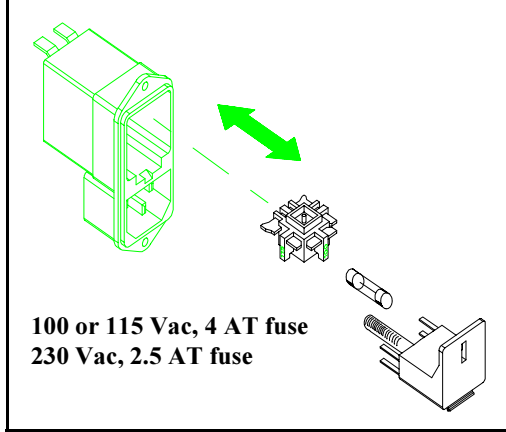

3 Rotate the power-line voltage selector until the correct voltage appears.

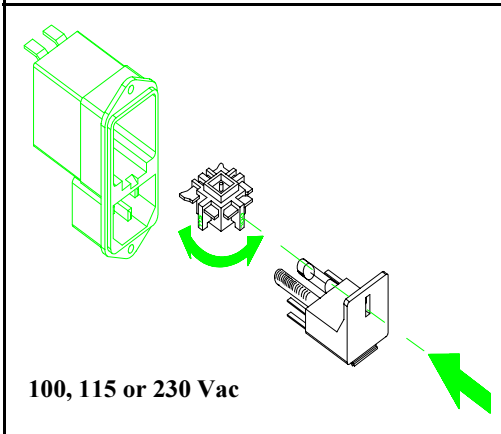

4 Replace the power-line voltage selector and the fuse-holder assembly in the rear panel.

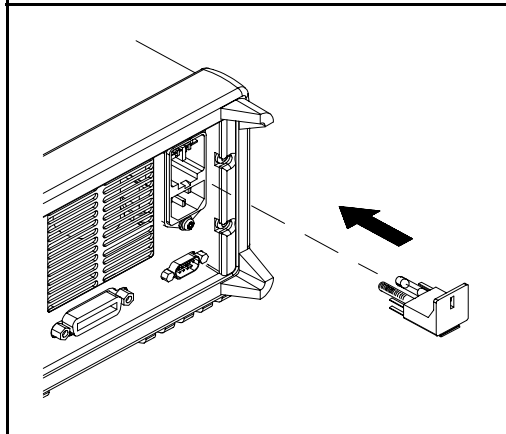

Install the correct fuse and verify that the correct line voltage appears in the window.

To Check the Rated Voltages of the Power Supply

The following procedures check to ensure that the power supply develops its rated voltage outputs with no load and properly responds to operation from the front panel.

For each step, use the keys shown on the left margins.

Power

1 Turn on the power supply.

The power supply will go into the *power-on / reset* state; the output is disabled (the **OFF** annunciator turns on); the 15V/7A range is selected (the **+15V** annunciator turns on); and the knob is selected for *voltage* control.

Output On/Off

2 Enable the outputs.

The **OFF** annunciator turns off and the **15V**, **OVP**, **OCP** and **CV** annunciators are lit. The *blinking* digit can be adjusted by turning the knob. Notice that the display is in the meter mode. "Meter mode" means that the display shows the actual output voltage and current.

3 Check that the front-panel voltmeter properly responds to knob control.

Turn the knob clockwise or counter clockwise to check that the voltmeter responds to knob control and the ammeter indicates nearly zero.

4 Ensure that the voltage can be adjusted from zero to the maximum rated value. ¹

Adjust the knob until the voltmeter indicates 0 volts and then adjust the knob until the voltmeter indicates 15.0 volts.

¹You can use the resolution selection keys to move the blinking digit to the right or left when setting the voltage.

To Check the Rated Currents of the Power Supply

The following procedures check to ensure that the power supply develops its rated current outputs with a short and properly responds to operation from the front panel.

For each step, use the keys shown on the left margin.

Power

1 Turn on the power supply.

The power supply will go into the *power-on / reset* state; the output is disabled (the **OFF** annunciator turns on); the 15V/7A range is selected (the **15V** annunciator turns on); and the knob is selected for *voltage* control.

2 Connect a short across (+) and (-) output terminals with an insulated test lead.

Output On/Off

3 Enable the outputs.

The **OFF** annunciator turns off and the **15V**, **OVP** and **OCP** annunciator turns on. The **CV** or **CC** annunciator is lit depending on the resistance of the test lead. The *blinking* digit can be adjusted by turning the knob. Notice that the display is in the meter mode. "Meter mode" means that the display shows the actual output voltage and current.

Display Limit

4 Adjust the voltage limit value to 1.0 volt.

Set the display to the *limit* mode (the **Lmt** annunciator will be *blinking*). Adjust the voltage limit to 1.0 volt to assure CC operation. The **CC** annunciator will light.

Volt/Curr

5 Check that the front-panel ammeter properly responds to knob control.

Set the knob to the *current* control, and turn the knob clockwise or counter clockwise when the display is in the meter mode (the **Lmt** annunciator is off). Check that the ammeter responds to knob control and the voltmeter indicates nearly zero (actually, the voltmeter will show the voltage drop caused by the test lead).

- 6 **Ensure that the current can be adjusted from zero to the maximum rated value.**  ¹

Adjust the knob until the ammeter indicates 0 amps and then until the ammeter indicates 7.0 amps.

2

Note

*If an error has been detected during the output checkout procedures, the **ERROR** annunciator will turn on. See "Error Messages" for more information, starting on page 121 in chapter 5 of the User's Guide.*

¹*You can use the resolution selection keys to move the blinking digit to the right or left when setting the current.*

To Use the Power Supply in Constant Voltage Mode

To set up the power supply for constant voltage (CV) operation, proceed as follows.

For each step, use the keys shown on the left margin.

1 Connect a load to the desired output terminals.

With power-off, connect a load to the desired output terminals.

Power

2 Turn on the power supply.

The power supply will go into the *power-on/reset* state; output is disabled (the **OFF** annunciator turns on); the 15V/7A range is selected (the **15V** annunciator turns on); and the knob is selected for *voltage* control.

To operate the power supply in the 30V/4A range, press the **30V, 4A** key before proceeding to the next step. The 30V annunciator turns on.

Display Limit

3 Set the display for the limit mode.

Notice that the **Limit** annunciator blinks, indicating that the display is in the limit mode. When the display is in the *limit* mode, you can see the voltage and current limit values of the power supply.

In constant voltage mode, the voltage values between meter mode and limit mode are the same, but the current values are not. Moreover if the display is in the meter mode, you cannot see the change of current limit value when adjusting the knob. We recommend that you should set the display to "limit" mode to see the change of current limit value in constant voltage mode whenever adjusting the knob.

Volt/Curr

4 Adjust the knob for the desired current limit. ¹

Check that the **Lmt** annunciator still blinks. Set the knob for *current* control. The second digit of ammeter will be *blinking*. The blinking digit can be changed using the resolution selection keys and the blinking digit can be adjusted by turning the knob. Adjust the knob to the desired current limit.

¹You can use the resolution selection keys to move the blinking digit to the right or left when setting current.

Volt/Curr

5 Adjust the knob for the desired output voltage.  ¹

Check that the **Limit** annunciator still blinks. Set the knob for *voltage* control. The second digit of the voltmeter will be *blinking*. Change the blinking digit using the resolution selection keys and adjust the knob to the desired output voltage.

Display Limit

6 Return to the meter mode.

Press the `Display Limit` key or let the display time-out after several seconds to return to the meter mode. Notice that the **Limit** annunciator turns off and the display shows "OUTPUT OFF" message.

Output On/Off

7 Enable the outputs

The **OFF** annunciator turns off and the **15V** or **30V**, **OVP**, **OCV**, and **CV** annunciators are lit. Notice that the display is in the meter mode. In the *meter* mode, the display shows the actual output voltage and current.

8 Verify that the power supply is in the constant voltage mode.

If you operate the power supply in the constant voltage (CV) mode, verify that **CV** annunciator is lit. If the **CC** annunciator is lit, choose a *higher* current limit.

Note

During actual CV operation, if a load change causes the current limit to be exceeded, the power supply will automatically crossover to constant current mode at the preset current limit and the output voltage will drop proportionately.

¹You can use the resolution selection keys to move the blinking digit to the right or left when setting voltage.

To Use the Power Supply in Constant Current Mode

To set up the power supply for constant current (CC) operation, proceed as follows.

For each step, use the keys shown on the left margin.

1 Connect a load to the output terminals.

With power-off, connect a load to the (+) and (-) output terminals.

Power

2 Turn on the power supply.

The power supply will go into the *power-on / reset* state; the output is disabled (the **OFF** annunciator turns on); the 15V/7A range is selected (the **15V** annunciator turns on); and the knob is selected for *voltage* control.

To operate the power supply in the 30V/4A range, press 30V, 4A key before proceeding to the next step. The **30V** annunciator turns on.

Display Limit

3 Set the display for the limit mode.

Notice that the **Limit** annunciator blinks, indicating that the display is in the limit mode. When the display is in the *limit* mode, you can see the voltage and current limit values of the selected supply.

In constant current mode, the current values between meter mode and limit mode are the same, but the voltage values are not. Moreover if the display is in the meter mode, you cannot see the change of voltage limit value when adjusting the knob. We recommend that you should set the display to "limit" mode to see the change of voltage limit value in constant current mode whenever adjusting the knob.

4 Adjust the knob for the desired voltage limit. ¹

Check that the **Limit** annunciator still blinks and the second digit of voltmeter *blinks* to indicate the knob is selected for voltage control. The blinking digit can be changed using the resolution keys and the blinking digit can be adjusted by turning the knob. Adjust the knob for the desired voltage limit.

¹You can use the resolution selection keys to move the blinking digit to the right or left when setting the voltage.

Volt/Curr

5 Adjust the knob for the desired output current.  ¹

Check that the **Limit** annunciator still blinks. Set the knob for *current* control. The second digit of the ammeter will be *blinking*. Change the blinking digit using the resolution selection keys and adjust the knob to the desired output current.

Display Limit

6 Return to the meter mode.

Press the `Display Limit` key or let the display time-out after several seconds to return to the meter mode. Notice that the **Limit** annunciator turns off and the display shows "OUTPUT OFF" message.

Output On/Off

7 Enable the outputs.

The **OFF** annunciator turns off and the **15V** or **30V**, **OVP**, **OC**, and **CC** annunciators are lit. Notice that the display is in the meter mode. In the *meter* mode, the display shows the actual output voltage and current.

8 Verify that the power supply is in the constant current mode.

If you operate the power supply in the constant current (CC) mode, verify that **CC** annunciator is lit. If the **CV** annunciator is lit, choose a *higher* voltage limit.

Note

During actual CC operation, if a load change causes the voltage limit to be exceeded, the power supply will automatically crossover to constant voltage mode at the preset voltage limit and the output current will drop proportionately.

¹You can use the resolution selection keys to move the blinking digit to the right or left when setting the voltage and current.

To Store and Recall the Instrument State

You can store up to three different operating states in *non-volatile* memory. This also enables you to recall the entire instrument with just a few key presses from the front panel.

The memory locations are supplied with the reset state from the factory for front panel operation. Refer to the description of *RST command, starting on page 94 in the User's Guide for more information.

The following steps show you how to store and recall an operating state.

1 Set up the power supply for the desired operating state.

The storage feature "remembers" the output range selection, the limit value settings of voltage and current, output on/off state, OVP and OCP on/off state, and OVP and OCP trip levels.

Store

2 Turn on the storage mode.

Three memory locations (numbered 1, 2, and 3) are available to store the operating states. The operating states are stored in *non-volatile* memory and are remembered when being recalled.



STORE 1

This message appears on the display for approximately 3 seconds.

3 Store the operating state in memory location "3".

Turn the knob to the right to specify the memory location 3.

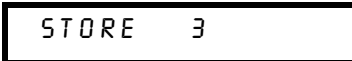

STORE 3

To cancel the store operation, let the display time-out after about 3 seconds or press any other function key except the Store key. The power supply returns to the normal operating mode and to the function pressed.

Store

4 Save the operating state.

The operating state is now stored. To recall the stored state, go to the following steps.

DONE

This message appears on the display for approximately 1 second.

Recall

5 Turn on the recall mode.

Memory location "1" will be displayed in the recall mode.

RECALL 1

This message appears on the display for approximately 3 seconds.

6 Recall the stored operating state. 

Turn the knob to the right to change the displayed storage location to "3".

RECALL 3

If this setting is not followed within 3 seconds with a Recall key stroke, the power supply returns to normal operating mode and will not recall the instrument state 3 from memory.

Recall

7 Restore the operating state.

The power supply should now be configured in the same state as when you stored the state on the previous steps.

DONE

This message appears on the display for approximately 1 second.

To Program Overvoltage Protection

Overvoltage protection guards the load against output voltages that reach a specified value greater than the programmed protection level. It is accomplished by shorting the output via an internal SCR when the trip level is set to equal or greater than 3 volts, or by programming the output to 1 volt when the trip level is set to less than 3 volts.

The following steps show how to set the OVP trip level, how to check OVP operation and how to clear overvoltage condition.

Setting the OVP Level and Enable the OVP Circuit

Power

1 Turn on the power supply.

The power supply will go into the *power-on / reset* state; the output is disabled (the **OFF** annunciator turns on); the 15V/7A range is selected (the **15V** annunciator turns on); and the knob is selected for *voltage* control.

Output On/Off

2 Enable the output.

The **OFF** annunciator turns off and the display will go to the meter mode.

Over Voltage

3 Enter the OVP menu and set the trip level.

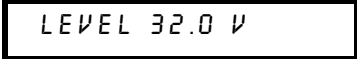

LEVEL 32.0 V

You will see the above message on the display when you enter the OVP menu. Adjust the knob for the desired OVP trip level.

Note

You cannot set the trip levels to lower than 1.0 volt.

Over Voltage

4 Enable the OVP circuit.



OVP ON

You will see the above message after pressing the `Over Voltage` key.

Over Voltage

5 Exit the OVP menu.



The "CHANGED" message is displayed for a second to show that the new OVP trip level is now in effect. If the OVP settings are not changed, "NO CHANGE" will be displayed. The power supply will exit the OVP menu and the display will return to the meter mode. Check that the **OVP** annunciator turns on.

Checking OVP Operation

To check OVP operation, raise the output voltage to near the trip point. Then very gradually increase the output by turning the knob until the OVP circuit trips. This will cause the power supply output to drop to near zero. The **OVP** annunciator is *blinking* and the **CC** annunciator turns on. The "OVP TRIPPED" message also appears on the display.

Clearing the Overvoltage Condition

When the OVP circuit trips (the "OVP TRIPPED" message is shown on the display), the **OVP** annunciator *blinks*. When it was caused by external voltage source such as a battery, disconnect it first. The following steps show how to clear the overvoltage conditions and get back to normal mode operation. In the following steps, the display will go back to "OVP TRIPPED" if you let the display time out after about several seconds.

`Over Voltage` or
`Display Limit`

1 **Readjust the OVP trip level or the output voltage level.** 

Lower the output voltage level below the OVP trip point after pressing the `Display Limit` or raise the OVP trip level by using the knob after pressing the `Over Voltage` key.

`Over Voltage`

2 **Move to the clear mode.** 

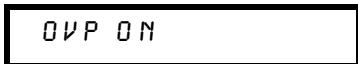

You will see the above message after pressing the `Over Voltage` key. If you changed the output voltage level, press the `Over Voltage` key twice. Turn the knob to the right until the "OVP CLEAR" appears on the display.

`Over Voltage`

3 Clear the overvoltage condition and exist this menu.

Now, when you press the `Over Voltage` key again, the "DONE" message is displayed for a second and the **OVP** annunciator will not *blink* any more. The output will return to meter mode.

To Program Overcurrent Protection

Overcurrent protection guards the load against output currents that reach a specified value greater than the programmed protection level. It is accomplished by programming the output current to zero.

The following steps show how to set the overcurrent protection trip level, how to check OCP operation and how to clear overcurrent condition.

Setting the OCP Level and Enable the OCP Circuit

Power

1 Turn on the power supply.

The power supply will go into the *power-on / reset* state; the output is disabled (the **OFF** annunciator turns on); the 15V/7A range is selected (the **15V** annunciator turns on); and the knob is selected for *voltage* control.

Output On/Off

2 Enable the output.

The **OFF** annunciator turns off and the display will go to the meter mode.

Over Current

3 Enter the OCP menu and set the trip level.

LEVEL 7.5 A

You will see the above message on the display when you enter the OCP menu. Adjust the knob for the desired OCP trip level.

Over Current

4 Enable the OCP circuit.

OCP ON

You will see above message after pressing the `Over Current` key .

Over Current

5 Exit the OCP menu.

CHANGED

The "CHANGED" message is displayed for a second to show that the new OCP trip level is now in effect. If the OCP settings are not changed, "NO CHANGE" will be displayed. The power supply will exit the OCP menu and the display will return to the meter mode. Check that the **OC**P annunciator turns on.

Checking OCP Operation

To check OCP operation, raise the output current to near the trip point. Then very gradually increase the output by turning the knob until OCP circuit trips. This will cause the power supply's output current to drop to zero and the **OC**P annunciator is *blinking*. The "OCP TRIPPED" message also appears on the display.

Clearing the Overcurrent Condition

When the OCP circuit trips (the "OCP TRIPPED" message is shown on the display), the **OC**P annunciator *blinks*. When it was caused by external voltage source such as a battery, disconnect it first. The following steps show how to clear the overcurrent conditions and get back to normal mode operation. In the following steps, the display will go back to "OCP TRIPPED" if you let the display time out after about several seconds.

`Over Current` or
`Display Limit`

1 Readjust the OCP trip level or the output current level. 

Lower the output current level below the OCP trip point after pressing the `Display Limit` or raise the OCP trip level by using the knob after pressing the `Over Current` key.

2 Move to the clear mode. 



You will see the above message after pressing the `Over Current` key. If you changed the output current level, press the `Over Current` key twice. Turn the knob to the right until the "OCP CLEAR" appears on the display.

`Over Current`

3 Clear the overcurrent condition and exit this menu.

Now, when you press the `Over Current` key again, the "DONE" message is displayed for a second and the **OC**P annunciator will not *blink* any more. The output will return to meter mode.

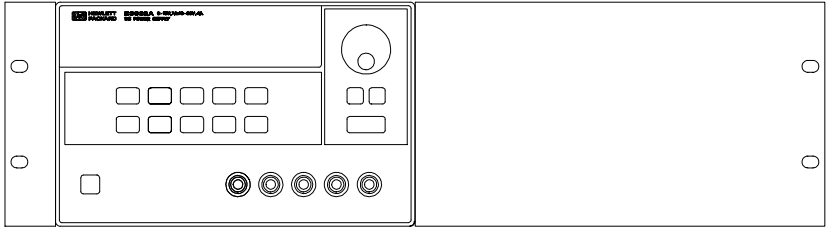
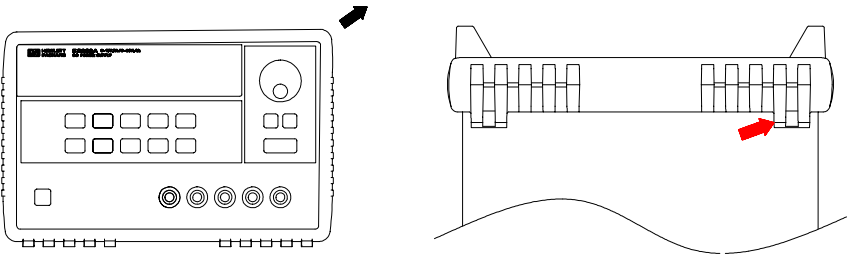

Chapter 2 Quick Start
To Rack Mount the Power Supply

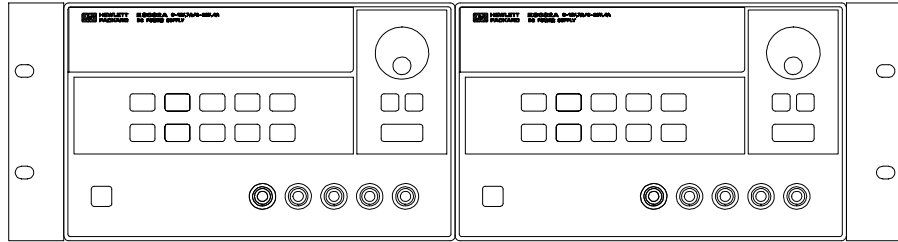

To Rack Mount the Power Supply

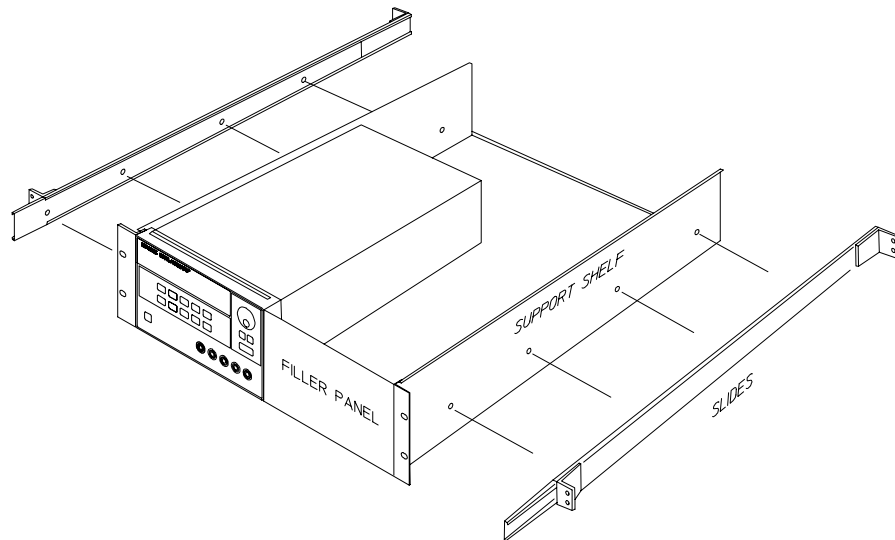

The power supply can be mounted in a standard 19-inch rack cabinet using one of three optional kits available. A rack-mounting kit for a single instrument is available as Option 1CM (P/N 5063-9243). Installation instructions and hardware are included with each rack-mounting kit. Any Agilent System II instrument of the same size can be rack-mounted beside the Agilent E3632A power supply. To rack mount the power supply, follow these procedures.

Chapter 2 Quick Start
To Rack Mount the Power Supply

Remove the front and rear bumpers before rack-mounting the power supply.

To remove the rubber bumper, stretch a corner and then slide it off.

To rack mount a single instrument, order adapter kit 5063-9243.

2

To rack mount two instrument side-by-side, order lock-link kit 5061-9694 and flange kit 5063-9214.

To install one or two instruments in a sliding support shelf, order shelf 5063-9256, and slide kit 1494-0015 (for a single instrument, also order filler panel 5002-4002)

Calibration Procedures

Calibration Procedures

This chapter contains procedures for verification of the power supply's performance and calibration (adjustment). The chapter is divided into the following sections:

- Agilent Technologies Calibration Services, page 43
- Calibration Interval, page 43
- Automating Calibration Procedures, page 44
- Recommended Test Equipment, page 44
- Test Considerations, page 45
- Performance Verification Tests, page 46
- Measurement Techniques, page 47
- Constant Voltage (CV) Verifications, page 49
- Constant Current (CC) Verifications, page 53
- Performance Test Record for Agilent E3632A, page 57
- Calibration Security Code, page 58
- Calibration Count, page 61
- Calibration Message, page 61
- General Calibration/Adjustment Procedure, page 62
- Aborting a Calibration in Progress, page 68
- Calibration Record for Agilent E3632A, page 69
- Error Messages, page 70
- Calibration Program, page 72

The performance verification tests for constant voltage (CV) and constant current (CC) operations use the power supply's specifications listed in chapter 1, "Specifications", starting on page 13.

Closed-Case Electronic Calibration The power supply features closed-case electronic calibration since no internal mechanical adjustments are required for normal calibration. The power supply calculates correction factors based upon the input reference value you enter. The new correction factors are stored in non-volatile memory until the next calibration adjustment is performed. (Non-volatile memory does not change when power has been off or after a remote interface reset.)

Agilent Technologies Calibration Services

When your power supply is due for calibration, contact your local Agilent Technologies Service Center for a low-cost calibration. The Agilent E3632A power supply is supported on calibration processes which allow Agilent Technologies to provide this service at competitive prices.

Calibration Interval

The power supply should be calibrated on a regular interval determined by the accuracy requirements of your application. A 1-year interval is adequate for most applications. Agilent Technologies does not recommend extending calibration intervals beyond 1 year for any application. Agilent Technologies recommends that complete re-adjustment should always be performed at the calibration interval. This will increase your confidence that the Agilent E3632A will remain within specification for the next calibration interval. This criteria for re-adjustment provides the best long-term stability.

Automating Calibration Procedures

You can automate the complete verification procedures outlined in this chapter if you have access to programmable test equipment. You can program the instrument configurations specified for each test over the remote interface. You can then enter readback verification data into a test program and compare the results to the appropriate test limit values.

You can also enter calibration constants from the remote interface. Remote operation is similar to the local front-panel procedure. You can use a computer to perform the adjustment by first selecting the required setup. The calibration value is sent to the power supply and then the calibration is initiated over the remote interface. The power supply must be unsecured prior to initiating the calibration procedure. An Agilent BASIC program for calibration over the GPIB interface is listed at the end of this chapter.

For further details on programming the power supply, see chapters 3 and 4 in the *Agilent E3632A User's Guide*.

Recommended Test Equipment

The test equipment recommended for the performance verification and adjustment procedures is listed below. If the exact instrument is not available, use the accuracy requirements shown to select substitute calibration standards.

Table 3-1 Recommended Test Equipment

Instrument	Requirements	Recommended Model	Use
GPIB Controller	Full GPIB capabilities	Agilent 82341C Interface card	Programming and readback accuracy
Oscilloscope	100 MHz with 20MHz bandwidth	Agilent 54602B	Display transient response and ripple & noise waveform
RMS Voltmeter	20 MHz		Measure rms ripple & noise
Digital Voltmeter	Resolution: 0.1 mV Accuracy: 0.01%	Agilent 34401A	Measure dc voltages
Electronic Load	Voltage Range: 50 Vdc Current Range: 10 Adc Open and Short Switches Transient On/Off	Agilent 6063B	Measure load and line regulations and transient response time.
Resistive Loads (R_L)	2.1 Ω , 200 W 7.5 Ω , 200 W		Measure ripple and noise
Current monitoring Resistor (Shunt)	0.01 Ω , 0.1%		Constant current test setup

Test Considerations

To ensure proper instrument operation, verify that you have selected the correct power-line voltage prior to attempting any test procedure in this chapter. page 24 for more information.

For optimum performance verification, all test procedures should comply with the following recommendations.

- Assure that the calibration ambient temperature is stable and between 20°C and 30°C.
- Assure ambient relative humidity is less than 80%.
- Allow a 1-hour warm-up period before verification or calibration.
- Keep cables as short as possible, consistent with the impedance requirements.

Caution

The tests should be performed by qualified personnel. During performance verification tests, hazardous voltages may be present at the outputs of the power supply.

Performance Verification Tests

The performance verification tests use the power supply's specifications listed in chapter 1, "Specifications", starting on page 13.

You can perform two different levels of performance verification tests:

- **Self-Test** A series of internal verification tests that provide high confidence that the power supply is operational.
- **Performance Verification Tests** These tests can be used to verify the power supply's specifications following repairs to specific circuits.

Self-Test

A *power-on* self-test occurs automatically when you turn on the power supply. This limited test assures you that the power supply is operational.

The *complete* self-test is enabled by pressing the `[Recall]` key (actually any front panel keys except the `[Error]` key) and the power-line switch simultaneously and then continuing to press the `[Recall]` key for 5 seconds. The complete self-test will be finished in 2 more seconds.

You can also perform a self-test from the remote interface (*see chapter 3 in the Agilent E3632A User's Guide*).

- If the self-test is successful, "PASS" is displayed on the front panel.
- If the self-test fails, "FAIL" is displayed and the **ERROR** annunciator turns on. If repair is required, see chapter 5, "Service", starting on page 89, for further details.
- If self-test passes, you have a high confidence that the power supply is operational.

Performance Verification Tests

These tests can be used to verify the power supply's specifications following repairs to specific circuits. The following sections explain all verification procedures in detail. All of the performance test specifications are shown in each test.

Measurement Techniques

Setup for Most Tests

Most tests are performed at the front terminals as shown in the following figure. Measure the dc voltage directly at the (+) and (-) terminals on the front panel.

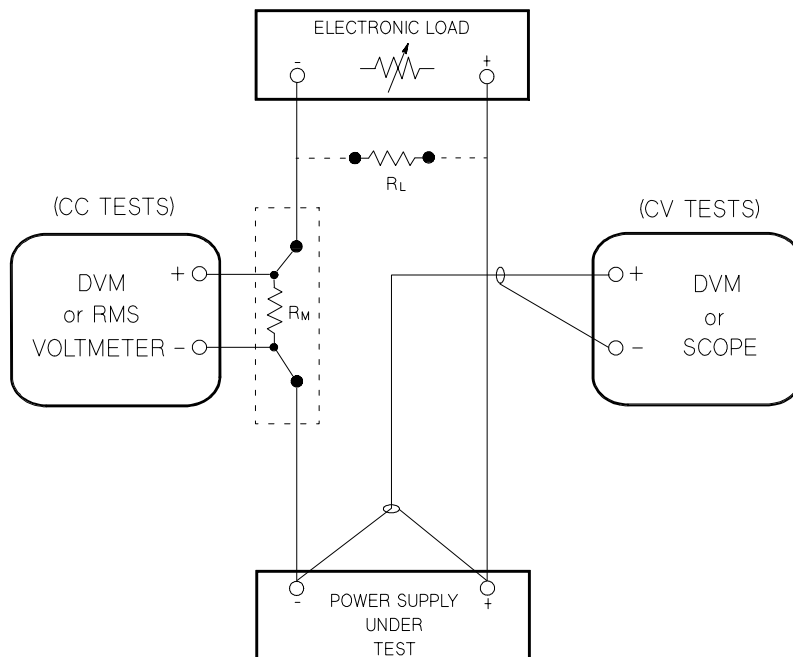

Figure 3-1. Performance Verification Test Setup

Electronic Load

Many of the test procedures require the use of a variable load resistor capable of dissipating the required power. Using a variable load resistor requires that switches be used to connect, disconnect, and short the load resistor. An electronic load, if available, can be used in place of a variable load resistor and switches. The electronic load is considerably easier to use than load resistors. It eliminates the need for connecting resistors or rheostats in parallel to handle power, it is much more stable than carbon-pile load, and it makes easy work of switching between load conditions as is required for the load regulation and load transient response tests. Substitution of the electronic load requires minor changes to the test procedures in this chapter.

Current-Monitoring Resistor

To eliminate output current measurement error caused by the voltage drops in the leads and connections, connect the current monitoring resistor between the (-) output terminal and the load as a four-terminal device. Connect the current-monitoring leads inside the load-lead connections directly at the monitoring points on the resistor element (see R_M in Figure 3-1).

Programming

Most performance tests can be performed only from the front panel. However, an GPIB or RS-232 controller is required to perform the voltage and current programming accuracy and readback accuracy tests.

The test procedures are written assuming that you know how to program the power supply either from the front panel or from an GPIB or RS-232 controller. Complete instructions on front panel and remote programming are given in the *Agilent E3632A User's Guide*.

Constant Voltage (CV) Verifications

Constant Voltage Test Setup

If more than one meter or a meter and an oscilloscope are used, connect each to the (+) and (-) terminals by a separate pair of leads to avoid mutual coupling effects. Use coaxial cable or shielded 2-wire cable to avoid noise pick-up on the test leads.

Voltage Programming and Readback Accuracy

This test verifies that the voltage programming and GPIB or RS-232 readback functions are within specifications. Note that the readback values over the remote interface should be identical to those displayed on the front panel.

You should program the power supply over the remote interface for this test to avoid round off errors.

- 1 Turn off the power supply and connect a digital voltmeter between the (+) and (-) terminals of the output to be tested as shown in Figure 3-1.
- 2 Turn on the power supply. Select the 30V/4A range and enable the outputs by sending the commands:

```
VOLT:RANG P30V  
OUTP ON
```

- 3 Program the output voltage to zero volt and current to full rated value (4.0A) by sending the commands:

```
VOLT 0  
CURR 4
```

- 4 Record the output voltage reading on the digital voltmeter (DVM). The reading should be within the limits of $(0V \pm 10 \text{ mV})$. Also, note that the **CV**, **Adrs**, **Limit**, and **Rmt** annunciators are on.
- 5 Readback the output voltage over the remote interface by sending the command:

```
MEAS:VOLT?
```

- 6 Record the value displayed on the controller. This value should be within the limits of $(\text{DVM} \pm 5 \text{ mV})$

- 7 Program the output voltage to full rated value (30.0V) by sending the command.

```
VOLT 30.0
```

- 8 Record the output voltage reading on the digital voltmeter (DVM). The readings should be within the limits of $(30V \pm 25mV)$.

- 9 Readback the output voltage over the remote interface by sending the command:

```
MEAS:VOLT?
```

- 10 Record the value displayed on the controller. This value should be within the limits of $(DVM \pm 20mV)$.

CV Load Regulation

This test measures the change in the output voltage resulting from a change in the output current from full to no load.

- 1 Turn off the power supply and connect a digital voltmeter between the (+) and (-) terminals of the output to be tested as shown in Figure 3-1.
- 2 Turn on the power supply. Select the 30V/4A range, enable the output, and set the display to the limit mode. When the display is in the limit mode, program the output current to the full rated value (4.0A) and the voltage to the full rated value (30.0V)
- 3 Operate the electronic load in constant current mode and set its current to 4.0A. Check that the front panel **CV** annunciator remains lit. If not lit, adjust the load so that the output current drops slightly until the **CV** annunciator lights. Record the output voltage reading on the digital voltmeter.
- 4 Operate the electronic load in open mode (input off). Record the output voltage reading on the digital voltmeter again. The difference between the digital voltmeter readings in steps (3) and (4) is the CV load regulation. The difference of the readings should be within the limit of 5mV.

CV Line Regulation

This test measures the change in output voltage that results from a change in ac line voltage from the minimum value (10% below the nominal input voltage) to maximum value (10% above the nominal input voltage).

- 1 Turn off the power supply and connect a digital voltmeter between the (+) and (-) terminals of the output to be tested as shown in Figure 3-1.

- 2 Connect the ac power line through a variable voltage transformer.
- 3 Turn on the power supply. Select the 30V/4A range, enable the output, and set the display to the limit mode. When the display is in the limit mode, program the current to the full rated value (4.0A) and the voltage to full rated value (30.0V).
- 4 Operate the electronic load in constant current mode and set its current to 4.0A. Check that the **CV** annunciator remains lit. If not lit, adjust the load so that the output current drops slightly until the **CV** annunciator lights.
- 5 Adjust the transformer to low line voltage limit (104 Vac for nominal 115 Vac, 90 Vac for nominal 100 Vac, or 207 Vac for nominal 230 Vac). Record the output reading on the digital voltmeter.
- 6 Adjust the autotransformer to high line voltage (127 Vac for nominal 115 Vac, 110 Vac for nominal 100 Vac, or 253 Vac for nominal 230 Vac). Record the voltage reading on the digital voltmeter. The difference between the digital voltmeter readings in steps (5) and (6) is the CV line regulation. The difference of the readings should be within the limit of 5mV.

Normal Mode Voltage Noise (CV Ripple and Noise)

The normal mode voltage noise is in the form of ripple related to the line frequency plus some random noise. The normal mode voltage noise is specified as the rms or peak-to-peak output voltage in a frequency range from 20 Hz to 20 MHz.

- 1 Turn off the power supply and connect the output to be tested as shown in Figure 3-1 to an oscilloscope (ac coupled) between (+) and (-) terminals. Set the oscilloscope to AC mode and bandwidth limit to 20 MHz. Connect a resistive load (7.5 Ω) as shown in Figure 3-1.
- 2 Turn on the power supply. Select the 30V/4A range, enable the output, and set the display to the limit mode. When the display is in the limit mode, program the current to the full rated value (4.0A) and the voltage to the full rated value (30.0V).
- 3 Check that the front panel **CV** annunciator remains lit. If not lit, adjust the load down slightly.
- 4 Note that the waveform on the oscilloscope does not exceed the peak-to-peak limit of 2 mV.
- 5 Disconnect the oscilloscope and connect an AC rms voltmeter in its place. The rms voltage reading does not exceed the rms limit of 0.35 mV.

Load Transient Response Time

This test measures the time for the output voltage to recover to within 15 mV of nominal output voltage following a load change from full load to half load, or half load to full load.

- 1 Turn off the power supply and connect the output to be tested as shown in Figure 3-1 with an oscilloscope. Operate the electronic load in constant current mode.
- 2 Turn on the power supply. Select the 30V/4A enable the outputs and set the display to the limit mode. When the display is in the limit mode, program the current to the full rated value (4.0A) and the voltage to the full rated value (3.0V).
- 3 Set the electronic load to transient operation mode between one half of the output's full scale value and the output's full rated value at a 1 kHz rate with 50% duty cycle.
- 4 Set the the oscilloscope for ac coupling, internal sync, and lock on either the positive or negative load transient.
- 5 Adjust the the oscilloscope to display transients as shown in Figure 3-2. Note that the pulse width (t_2-t_1) of the transients at 15 mV from the base line is no more than 50 μ sec for the output.

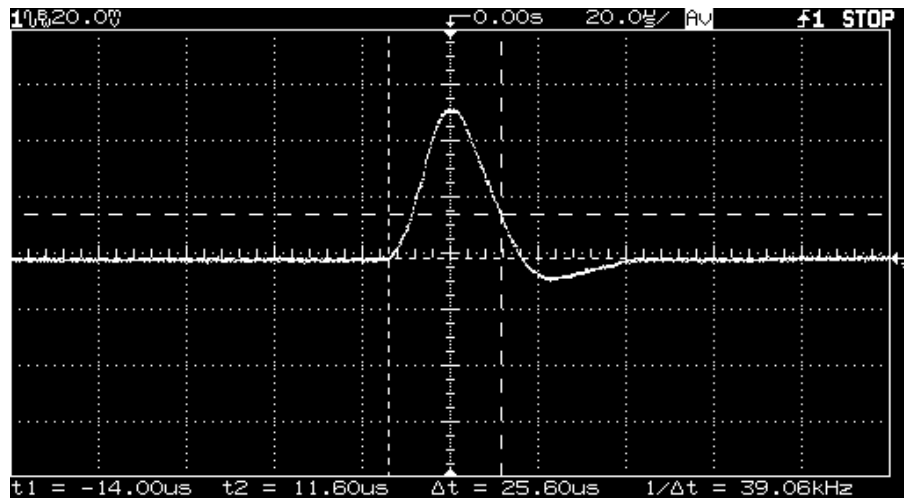

Figure 3-2. Transient Response Time

Constant Current (CC) Verifications

Constant Current Test Setup

Follow the general setup instructions in the "Measurement Techniques" section, starting on page 47 and the specific instructions will be given in the following paragraphs.

Current Programming and Readback Accuracy

This test verifies that the current programming and GPIB or RS-232 readback functions are within specifications. Note that the readback values over the remote interface should be identical to those displayed on the front panel. The accuracy of the current monitoring resistor must be 0.01% or better.

You should program the power supply over the remote interface for this test to avoid round off errors.

- 1 Turn off the power supply and connect a 0.01Ω current monitoring resistor (R_M) across the output to be tested and a digital voltmeter across the current monitoring resistor (R_M).
- 2 Turn on the power supply. Select the 15V/7A range and enable the output by sending the commands:

```
VOLT:RANG P15V  
OUTP ON
```

- 3 Program the output voltage to full rated voltage (15.0V) and output current to zero amp by sending the commands:

```
VOLT 15  
CURR 0
```

- 4 Divide the voltage drop (DVM reading) across the current monitoring resistor (R_M) by its resistance to convert to amps and record this value (I_O). This value should be within the limits of $(0A \pm 10mA)$. Also, note that the **CC**, **Adrs**, **Limit**, and **Rmt** annunciators are on.
- 5 Readback the output current over the remote interface by sending the command:

```
MEAS:CURR?
```

- 6 Record the value displayed on the controller. This value should be within the limit of $(I_O \pm 5mA)$.

- 7 Program the output current to the full rated value (7.0A) by sending the commands:

```
CURR 7.0
```

- 8 Divide the voltage drop (DVM reading) across the current monitoring resistor (R_M) by its resistance to convert to amps and record this value (I_O). This value should be within the limit of $(7A \pm 24mA)$.
- 9 Readback the output current over the remote interface by sending the command:

```
MEAS:CURR?
```

- 10 Record the value displayed on the controller. This value should be within the limit $(I_O \pm 15.5mA)$.

CC Load Regulation

This test measures the change in output current resulting from a change in the load from full-rated output voltage to short circuit.

- 1 Turn off the power supply and connect the output to tested as shown in Figure 3-1 with the digital voltmeter connected across the 0.01Ω current monitoring resistor (R_M).
- 2 Turn on the power supply. Select the 15V/7A range, enable the output, and set the display to the limit mode. When the display is in the limit mode, program the output voltage to the full rated value (15.0V) and the output current to the full rated value (7.0A).
- 3 Operate the electronic load in constant voltage mode and set its voltage to 15.0V. Check that the CC annunciator is on. If it is not, adjust the load so that the output voltage drops slightly. Record the current reading by dividing the voltage reading on the digital voltmeter by the resistance of the current monitoring resistor.
- 4 Operate the electronic load in short (input short) mode. Record the current reading again by dividing the voltage reading on the digital voltmeter by the resistance of the current monitoring resistor. The difference between the current readings in step (3) and (4) is the load regulation current. The difference of the readings should be within the limit of 0.95mA.

CC Line Regulation

This test measures the change in output current that results from a change in ac line voltage from the minimum value (10% below the nominal input voltage) to the maximum value (10% above nominal voltage).

- 1 Turn off the power supply and connect the output to be tested as shown in Figure 3-1 with the digital voltmeter connected across the current monitoring resistor (R_M).
- 2 Connect the ac power line through a variable voltage transformer.
- 3 Turn on the power supply. Select the 15V/7A range, enable the output, and set the display to the limit mode. When the display is in the limit mode, program the voltage to the full rated value (15.0V) and the current to the full rated value (7.0A).
- 4 Operate the electronic load in constant voltage mode and set its voltage to 15.0V. Check that the **CC** annunciator remains lit. If not lit, adjust the load so that the output voltage drops slightly until the **CC** annunciator lights.
- 5 Adjust the transformer to low line voltage limit (104 Vac for nominal 115 Vac, 90 Vac for nominal 100 Vac, or 207 Vac for nominal 230 Vac). Record the output current reading by dividing the voltage reading on the digital voltmeter by the resistance of the current monitoring resistor.
- 6 Adjust the transformer to 10% above the nominal line voltage (127 Vac for a 115 Vac nominal input, 110 Vac for a 100 Vac nominal input or 253 Vac for a 230 Vac nominal input). Record the current reading again by dividing the voltage reading on the digital voltmeter by the resistance of the current monitoring resistor. The difference between the current readings in step (5) and (6) is the load regulation current. The difference of the readings should be within the limit of 0.95mA.

3

Normal Mode Current Noise (CC Ripple and Noise)

The normal mode current noise is specified as the rms output current in a frequency range 20 Hz to 20 MHz with the power supply in constant current operation.

- 1 Turn off the power supply and connect the output to be tested as shown in Figure 3-1 with a load resistor (2.1Ω) across output terminals to be tested. Connect a rms voltmeter across the load resistor. Use only a resistive load for this test.

- 2 Turn on the power supply. Select the 15V/7A range, enable the output, and set the display to the limit mode. When the display is in the limit mode, program the current to full rated value (7.0A) and the voltage to the full rated value (15.0V).
- 3 The output current should be at the full-rated rating with the CC annunciator on. If not lit, adjust the load so that the output voltage drops slightly until the CC annunciator lights.
- 4 Divide the reading on the rms voltmeter by the load resistance to obtain rms current. The readings should be within the limit of 2mA.

Common Mode Current Noise

The common mode current is that ac current component which exists between the output or output lines and chassis ground. Common mode noise can be a problem for very sensitive circuitry that is referenced to earth ground. When a circuit is referenced to earth ground, a low level line-related ac current will flow from the output terminals to earth ground. Any impedance to earth ground will create a voltage drop equal to the output current flow multiplied by the impedance.

- 1 Turn off the power supply and connect a 100K Ω resistor (R_S) and a 2200 pF capacitor in parallel between the (-) terminal and chassis ground.
- 2 Connect a digital voltmeter across R_S .
- 3 Turn on the power supply. Select the 15V/7A range, enable the output, and set the display to the limit mode. When the display is in the limit mode, program the output to the full rated value (15.0V and 7.0A).
- 4 Record the voltage across R_S and convert it to current by dividing by the resistance (DVM reading/100K Ω). Note that the current is less than 1.5 μ A.

Performance Test Record for Agilent E3632A

CV Performance Test Record

Test Description	Actual Result	Specifications	
		Upper Limit	Lower Limit
CV Programming Accuracy @ 0 volts (DVM reading)		+0.0100 V	-0.0100 V
CV Readback Accuracy @ 0 volts		DVM + 0.0050 V	DVM - 0.0050 V
CV Programming Accuracy @ Full Scale (DVM reading)		+30.025V	29.9750 V
CV Readback Accuracy @ Full Scale		DVM + 0.0200 V	DVM - 0.0200 V
CV Load Regulation		Maximum change: <5 mV	
CV Line Regulation		Maximum change: <5 mV	
CV Ripple/Noise		<2 mV p-p, 0.35 mV rms	
Load Transient Response Time		<50 μ sec	



CC Performance Test Record

Test Description	Actual Result	Specifications	
		Upper Limit	Lower Limit
CC Programming Accuracy @ 0 amps (I_O)		+0.0100 A	-0.0100 A
CC Readback Accuracy @ 0 amps		I_O + 0.0050 A	I_O - 0.0050 A
CC Programming Accuracy @ Full Scale (I_O)		7.0240 A	6.9760 A
CC Readback Accuracy @ Full Scale		I_O + 0.0155 A	I_O - 0.0155 A
CC Load Regulation		Maximum change: <0.95 mA	
CC Line Regulation		Maximum change: <0.95 mA	
CC Ripple/Noise		<2 mA	
Common Mode Current Noise		<1.5 μ A rms	

Calibration Security Code

This feature allows you to enter a security code (electronic key) to prevent accidental or unauthorized calibrations of the power supply. When you first receive your power supply, it is secured. Before you can calibrate the power supply, you *must* unsecure it by entering the correct security code. A procedure to unsecure the power supply is given on the following page.

- *The security code is set to "HP003632" when the power supply is shipped from the factory.* The security code is stored in *non-volatile* memory, and *does not* change when power has been off or after a remote interface reset.
- To secure the power supply from the *remote interface*, the security code may contain up to 12 alphanumeric characters as shown below. The first character *must* be a letter, but the remaining characters can be letters or numbers. You do not have to use all 12 characters but the first character must always be a *letter*.

A _ _ _ _ _ _ _ _ _ _ (12 characters)

- To secure the power supply from the remote interface so that it can be unsecured from the front panel, use the eight-character format shown below. The first two characters must be "H P" and the remaining characters must be numbers. Only the last six characters are recognized from the front panel, but all eight characters are required. *To unsecure the power supply from the front panel, omit the "H P" and enter the remaining numbers as shown on the following pages.*

H P _ _ _ _ _ (8 characters)

- *If you forget your security code, you can disable the security feature by adding a jumper inside the power supply, and then entering a new code. See the procedure on page 60.*

To Unsecure the Power Supply for Calibration

The power supply can use a calibration security code to prevent unauthorized or accidental calibration. This procedure shows you how to unsecure the power supply for calibration from the front panel.

Calibrate

Power

1 Turn on the front-panel calibration mode.



SECURED

Turn on the calibration mode by pressing the "Calibrate" key while simultaneously turning on the power supply then continue to hold the "Calibrate" key for about 5 seconds until a beep is heard.

If the power supply is secured, you will see the above message from the front panel for approximately one second. The "CAL MODE" message is then displayed on the front panel.

3

Secure

2 Move to the security code by pressing the "Secure" key.



000000 CODE

3 Enter the security code using the knob and resolution selection keys.



003632 CODE

The security code is set to "Agilent Technologies003632" when the power supply is shipped from the factory. The security code is stored in *non-volatile* memory and *does not* change when the power has been off or after a remote interface reset.

To enter the security code from the front panel, enter only the last six digits. To enter the security code from the remote interface, you may enter up to 12 characters.

Use the resolution selection keys to move left or right between digits. Use the knob to change the digits. Notice that the security code may be different if the security code has been changed from the default setting.

Secure

4 Unsecure the power supply.

UNSECURED

The power supply is unsecured when you press the Secure key. You will see the above message from the front panel for one second. The "CAL MODE" message is displayed on the front panel after above message.

Power

5 Turn off the calibration mode.

Turn off the power supply to exit the calibration mode.

To re-secure the power supply (following calibration), perform this procedure again.

To Unsecure the Power Supply Without the Security Code

To unsecure the power supply without the correct security code (when you forget the security code), follow the steps below. See "Electrostatic Discharge (ESD) Precautions" in chapter 5 before beginning this procedure.

- 1 Disconnect the power cord and *all* load connections from front terminals.
- 2 Remove the instrument cover. Refer to the disassembly drawing on page 119.
- 3 Connect the power cord and turn on the *calibration mode* by pressing the "Calibrate" key while simultaneously turning on the power supply then continue to hold the "Calibrate" key for about 5 seconds until a beep is heard. Be careful not to touch the power line connections.
- 4 Apply a short between the two exposed metal pads on JP5 (located near U13). The JP5 is outlined with a circle on the component locator drawing on page 120.
- 5 While maintaining the short, move to the security code and enter any unsecure code in the calibration mode. The power supply is now unsecured.
- 6 Remove the short at JP5. (An error occurs if not removed.)
- 7 Turn off and reassemble the power supply.
Now you can enter a new security code. Be sure you take note of the new security code.

Calibration Count

The calibration count feature provides an independent "serialization" of your calibrations. You can determine the number of times that your power supply has been calibrated. By monitoring the calibration count, you can determine whether an unauthorized calibration has been performed. Since the value increments by one for each *calibration parameter* (see Table 3-2 on the next page), a complete calibration increases the value by 5 counts.

- The calibration count is stored in *non-volatile* memory and *does not* change when power has been off or after a remote interface reset. Your power supply was calibrated before it left the factory. When you receive the power supply, read the calibration count to determine its value.
- The calibration count increments up to a maximum of 32,767 after which it wraps around to 0. No way is provided to program or reset the calibration count.

Calibration Message

You can use the calibration message feature to record calibration information about your power supply. For example, you can store such information as the last calibration date, the next calibration due date, the power supply's serial number, or even the name and phone number of the person to contact for a new calibration.

You can record and read information in the calibration message from the remote interface only.

- The calibration message may contain up to 40 characters.
- The calibration message is stored in *non-volatile* memory and *does not* change when power has been off or after a remote interface reset.

General Calibration/Adjustment Procedure

The calibration procedures from the front panel are described in this section. For voltage calibration, *disconnect* all loads from the power supply and connect a DVM across the output terminals. For current calibration, *disconnect* all loads from the power supply, *connect* an appropriate current monitoring resistor (0.01Ω) across the output terminals, and connect a DVM across the terminals of the monitoring resistor.

Note that the power supply should be calibrated after 1-hour warm-up with no load connected.

The following table shows calibration parameters and points which should be used to calibrate the output voltage and current.

Table 3-2. Parameters for Calibration

Calibration Parameter	Voltage/ Current	Calibration Point mnemonic
CAL SETUP 1	Voltage	V LO
		V MI
		V HI
CAL SETUP 2	OVP	None
CAL SETUP 3	Current	V LO
		I MI
		V HI
CAL SETUP 4	OCP	None

Note

You can terminate any CAL SETUP without changing its calibration constants by turning off power.

Note

Perform the voltage calibration prior to the OVP calibration and the current calibration prior to the OCP calibration.

To calibrate the output voltages and currents of the power supply from the front panel, proceed as follows:

1 Unsecure the power supply.

To calibrate the voltage and current, you must *unsecure* the power supply according to the procedure given on page 59.

2 Disconnect all loads from the power supply and connect a DVM across output terminals.

Calibrate

Power

3 Turn on the calibration mode.

CAL MODE

Turn on the calibration mode by pressing the "Calibrate" key while simultaneously turning on the power supply then continue to hold the "Calibrate" key for about 5 seconds until a beep is heard. Make sure that the power supply is in "CV" mode. If the power supply is not in "CV" mode, an error occurs.

3

Voltage and OVP Calibration

Calibrate

4 Move down a level to the voltage calibration mode.

CAL SETUP 1

The display shows the above message to indicate that the power supply is ready for the voltage calibration.

Calibrate

5 Calibrate DAC and select the low voltage calibration point.

30 LEFT

The "START BITCAL" message is displayed for about 3 seconds to indicate that the power supply is ready for DAC calibration. Then it counts down numbers from 30 to 0.



V LO +0.5000 V

Then, the display shows the low voltage calibration point.

6 Read the DVM and change the low voltage value on the display to match the measured voltage.

For example, if the DVM reading is 0.4500 V, adjust the voltage to 0.4500 V using the knob and resolution selection keys.

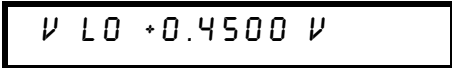

V LO +0.4500 V

Calibrate

7 Pressing the "Calibrate" key saves the change and selects the middle voltage calibration point.



V MI +15.000V

If the entered number is within an acceptable range, an "ENTERED" message appears for one second. If the entered number is not correct, an "MIN VALUE" "MAX VALUE" message appears for one second and the display shows the low voltage calibration point again. The display now shows the middle voltage calibration point.

8 Read the DVM and change the middle voltage value on the display to match the measured voltage.

For example, if the DVM reads 14.995 V, adjust the voltage to 14.995 V using the knob and arrow keys.

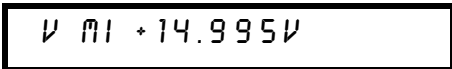

V MI +14.995V

Calibrate

9 Pressing the "Calibrate" key saves the change and selects the high voltage calibration point.



V HI 29.500 V

If the entered number is within an acceptable range, a "ENTERED" message appears for one second. If the entered number is not correct, an "MIN VALUE" or "MAX VALUE" message appears for one second and the display shows the middle voltage calibration point again. The display now shows the high voltage calibration point.

10 Read the DVM and change the first voltage value on the display to match the measured voltage.

For example, if the DVM reads 28.995V, adjust the current to 28.995 V using the knob and arrow keys.

V HI 28.995 V



Calibrate

11 Pressing the "Calibrate" key saves the new voltage calibration constants, and goes to the OVP calibration mode.

CAL SETUP 2

A "CALIBRATING" message appears for one second to indicate that the voltage calibration is progressing and new voltage calibration constants of "SETUP 1" are stored. Then, the display shows above message to indicate that the power supply is ready for the OVP calibration.

If the calibration fails, a "DAC CAL FAIL" or "ADC CAL FAIL" message appears for one second and the display shows the "CAL SETUP 1" for voltage calibration again.

Current and OCP Calibration

Connect an appropriate shunt (0.01Ω) across the output terminals, and connect a digital voltmeter across the shunt resistor for the current calibration.

- 12 Pressing the "Calibrate" key saves the new calibration constants for OVP circuit and goes to the current calibration mode.**



CAL SETUP 3

A "CALIBRATING" message appears for about several seconds to indicate that the OVP calibration is progressing and new calibration constants of "SETUP 2" are stored. Then, the display shows the above message to indicate that the power supply is ready for the current calibration.

If the calibration fails, a "OVP CAL FAIL" message appears for one second and the display shows the "CAL SETUP 2" for OVP calibration again.

Calibrate

- 13 Select the low current calibration point.**



1 LO 0.200 A

The display shows the low current calibration point.

- 14 Read the DVM and change the low current value on the display to match the computed current (DVM reading ÷ by shunt resistance).**

For example, if the computed value is 0.199 A, adjust the current to 0.199 A using the knob and arrow keys.

Notice that you should wait for the DVM reading to stabilize for accurate calibration.

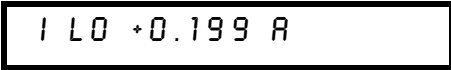

1 LO +0.199 A

Calibrate

- 15 Pressing the "Calibrate" key saves the change and selects the middle current calibration point.**

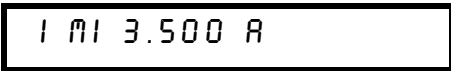

1 MI 3.500 A

If the entered number is within an acceptable range, an "ENTERED" message appears for one second. If the entered number is not correct, an "MIN VALUE" or "MAX VALUE" message appears for one second and the display shows the low current calibration point again. The display now shows the middle current calibration point.

- 16 Read the DVM and change the middle current value on the display to match the computer current (DVM reading ÷ by shunt resistance).**

For example, if the computered value is 3.499 A, adjust the current to 3.499 A using the knob and arrow keys.

Notice that you should wait for the DVM reading to stabilize for accurate calibration.

1 M 3.499 A

Calibrate

- 17 Pressing the "Calibrate" key saves the change and selects the high current calibration point.**

1 H 6.900 A

If the entered number is within an acceptable range, an "ENTERED" message appears for one second. If the entered number is not correct, an "MIN VALUE" or "MAX VALUE" message appears for one second and the display shows the middle current calibration point again. The display now shows the high current calibration point

- 18 Read the DVM and change the high current value on the display to match the computed current (DVM reading ÷ by shunt resistance).**

For example, if the computed value is 6.899 A, adjust the current to 6.899 A using the knob and arrow keys.

Notice that you should wait for the DVM reading to stabilize for accurate calibration.

1 H 6.899 A

Calibrate

- 19 Pressing the "Calibrate" key saves the new calibration constants for the output current and goes to the OCP calibration mode.**



CAL SETUP 4

A "CALIBRATING" message appears for one second to indicate that the current calibration is progressing and new calibration constants of "SETUP 3" are stored. Then, the display shows the above message to indicate that the power supply is ready for the OCP calibration.

If the calibration fails, an "DAC CAL FAIL" or "ADC CAL FAIL" message appears for one second and the display shows the "CAL SETUP 3" for current calibration again.

Calibrate

- 20 Pressing the "Calibrate" key saves the new OCP calibration constants and return to the calibration mode.**



CAL MODE

A "CALIBRATING" message appears for several seconds to indicate that the OCP calibration is progressing and new OCP calibration constants of "SETUP 4" are stored. Then the display will return to the calibration mode.

Power

- 21 Turn off the power supply to exit the calibration mode.**

Aborting a Calibration in Progress

Sometimes it may be necessary to abort a calibration after the procedure has already been initiated. You can abort a calibration at any time by turning the power supply off from the front panel. When performing a calibration from the remote interface, you can abort a calibration by issuing a remote interface device clear message or by pressing the front-panel "Local" key.

Calibration Record for Agilent E3632A

Step	Calibration Description	Measurement Mode (DVM)	Supply being Adjusted
1	Unsecure the power supply (see page 59).		
2	Turn on "CAL MODE"(simultaneously press "Calibrate" and "Power" keys) until it beeps.		
3	Move down menu to "CAL SETUP 1" (press "Calibrate" key).		Voltage Calibration
4	Calibrate DAC and select the low point for voltage calibration; "START BITCAL" appears for 3 seconds and the display counts down numbers from 30 to 0. Then, "V LO 0.5000 V" appears on the display(press "Calibrate" key and wait about 30 seconds; then change the display to match the DVM reading).	V	DAC and low voltage point calibration
5	"V MI 15.000 V" appears on the display (press "Calibrate" key; then change the display to match the DVM reading).	V	Middle voltage point calibration
6	"V HI 29.500 V" appears on the display (press "Calibrate" key; then change the display to match the DVM reading).	V	High voltage point calibration
7	"CAL SETUP 2" now appears on the display (press "Calibrate" key).	V	OVP calibration
8	"CAL SETUP 3" now appears on the display (press "Calibrate" key; then connect 0.01 Ω resistor across the output terminals).		Current calibration
9	"I LO 0.200 A" appears on the display (press "Calibrate" key; then change the display to match the computed current through 0.01 Ω resistor).	A	Low current point calibration
10	"I MI 3.500 A" appears on the display (press "Calibrate" key; then change the display to match the computed current through 0.01 Ω resistor).	A	Middle current point calibration
11	"I HI 6.9000 A" appears on the display (press "Calibrate" key; then change the display to match the computed current through 0.01 Ω resistor).	A	High current point calibration
12	"CAL SETUP 4" now appears on the display (press "Calibrate" key).	A	OCP calibration
13	Press "Calibrate" key, then press "Power" switch.		Exit CAL MODE



Error Messages

The following tables are abbreviated lists of error messages for the E3632A. The errors listed are the most likely errors to be encountered during calibration and adjustment. A more complete list of error messages and descriptions is contained in chapter 5 of the E3632A User's Guide.

System Error Messages

Error	Error Message
-330	Self-test failed
-350	Too many errors
501	Isolator UART framing error
502	Isolator UART overrun error
511	RS-232 framing error
512	RS-232 overrun error
513	RS-232 parity error
514	Command allowed only with RS-232
521	Input buffer overflow
522	Output buffer overflow
550	Command not allowed in local

Self-Test Error Messages

Error	Error Message
601	Front panel does not respond
602	RAM read/write failed
603	A/D sync stuck
604	A/D slope convergence failed
605	Cannot calibrate rundown gain
606	Rundown gain out of range
607	Rundown too noisy
608	Serial configuration readback failed
624	Unable to sense line frequency
625	I/O processor does not respond
626	I/O processor failed self-test
630	Fan test failed
631	System DAC test failed
632	Hardware test failed

Calibration Error Messages

Error	Error Message
701	Cal security disabled by jumper
702	Cal secured
703	Invalid secure code
704	Secure code too long
705	Cal aborted
708	Cal output disabled
712	Bad DAC cal data
713	Bad readback cal data
714	Bad OVP cal data
715	Bad OCP cal data
716	Bad OVP DNL error correction data
717	Cal OVP or OCP status enabled
740	Cal checksum failed, secure state
741	Cal checksum failed, string data
742	Cal checksum failed, store/recall data in location 0
743	Cal checksum failed, store/recall data in location 1
744	Cal checksum failed, store/recall data in location 2
745	Cal checksum failed, store/recall data in location 3
746	Cal checksum failed, DAC cal constants
747	Cal checksum failed, readback cal constants
748	Cal checksum failed, GPIB address
749	Cal checksum failed, internal data
750	Cal checksum failed, DAC DNL error correction data



Calibration Program

This section contains an Agilent BASIC program for calibration over the GPIB interface. This program makes software adjustments to the E3632A power supply using a current shunt and a digital multimeter which is connected to the controller. In this program a 0.01 ohm current shunt is used. Be sure to change the value of the variable "Current_shunt" to the value of the current shunt used and the GPIB address for the power supply and the digital voltmeter.

```
10      !
20      ! This program was written on a PC with Agilent Basic for Windows.
30      ! It will make software adjustments to the E3632A Power Supply
40      ! on the GPIB bus using a Agilent 34401A Digital Multimeter and a
50      ! current shunt. In the program a 0.01 ohm current shunt is
60      ! used to measure current. Be sure to change the value of
70      ! the variable 'Current_shunt' to the value of the current
80      ! shunt used.
90      !
100     CLEAR SCREEN
110     DIM Cal_msg$(40),Error$(40),Sec_code$(10)
120     REAL Dmm_rdg,Current_shunt
130     Current_shunt=.01           ! Current Shunt value in Ohms
140     Sec_code$="HP003632"       ! Assign the security code
150     ASSIGN @Dmm TO 722        ! Assign address 22 to the Dmm
160     ASSIGN @Pwrsupply TO 705  ! Assign address 5 to the Power Supply
170     CLEAR 7                   ! Clear GPIB, Dmm and Power Supply
180     OUTPUT @Pwrsupply;"*CLS"  ! Clear Power Supply errors
190     OUTPUT @Dmm;"*RST"       ! Reset Dmm
200     OUTPUT @Pwrsupply;"*RST"  ! Reset Power Supply
210     OUTPUT @Pwrsupply;"CAL:STR?" ! Read the calibration message
220     ENTER @Pwrsupply;Cal_msg$
230     PRINT TABXY(5,2),"CaLibration message of Power Supply is: ";Cal_msg$
240     !
250     ! Set the Calibration security to off, and check to be sure
260     ! it is off. If not successful, print message to screen and end.
270     !
280     OUTPUT @Pwrsupply;"VOLT:PROT:STAT OFF"
290     OUTPUT @Pwrsupply;"CURR:PROT:STAT OFF"
300     OUTPUT @Pwrsupply;"CAL:SEC:STAT OFF, ";Sec_code$
310     OUTPUT @Pwrsupply;"CAL:SEC:STAT?"
320     ENTER @Pwrsupply;A
330     IF A=1 THEN
340         PRINT TABXY(5,5),"***** Unable to Unsecure the Power supply *****"
350         GOTO 2290
360     END IF
```

Chapter 3 Calibration Procedures Calibration Program

continued

```
370  !
380  ! Perform the DAC error correction, voltage calibration and OVP calibration.
390  ! Alert the operator to hook up the connection before calibrating.
400  !
410  ! Alert operator to connect lead
420  PRINT TABXY(10,10),"*****"
430  PRINT TABXY(10,11)," Prepare for E3632A DAC DNL error correction and"
440  PRINT TABXY(10,12)," Voltage/OVP calibration. Connect the output to the DMM."
450  PRINT TABXY(10,13)," Observe Polarity!"
460  PRINT TABXY(10,14),"*****"
470  PRINT TABXY(10,16),"Press 'C' to Continue, 'I' to go to CURRENT calibration or
480  PRINT TABXY(10,17)," 'X' to eXit, then press 'Enter'"
490  Ch$="C"
500  INPUT Ch$
510  IF Ch$="X" OR Ch$="x" THEN GOTO 2250
520  IF Ch$="I" OR Ch$="i" THEN
530      CLEAR SCREEN
540      GOTO 1460
550  END IF
560  CLEAR SCREEN
570  PRINT TABXY(10,7),"BEGIN DAC ERROR CORRECTION"
580  WAIT 4
590  CLEAR SCREEN
600  OUTPUT @Pwrsupply;"OUTP ON"           ! Turn on Power Supply output
610  OUTPUT @Pwrsupply;"CAL:DAC:ERROR"     ! Perform DAC DNL error correction
620  WAIT 29                               ! Allow DAC error correction to finish
630  OUTPUT @Pwrsupply;"OUTPUT OFF"       ! Turn off Power Supply output
640  OUTPUT @Pwrsupply;"SYST:ERR?"
650  ENTER @Pwrsupply;Error$
660  !
670  ! Check to see if there is an error.  If there is an error,
680  ! display the error and exit the program.
690  !
700  CLEAR SCREEN
710  IF Error$="+0,""No error"" THEN
720      PRINT "DAC DNL Error Correction completed for Power Supply "
730  ELSE
740      PRINT "ERROR: ";Error$;"DAC DNL Error not corrected "
750      BEEP
760      GOTO 2250
770  END IF
780  PRINT TABXY(10,5),"DAC DNL ERROR CORRECTION COMPLETE"
790  PRINT TABXY(10,7),"BEGIN VOLTAGE CALIBRATION"
800  WAIT 4
810  OUTPUT @Pwrsupply;"OUTPUT ON"
820  CLEAR SCREEN
830  OUTPUT @Pwrsupply;"CAL:VOLT:LEV MIN"  ! set output to minimum cal value
840  WAIT 2                                ! allow output to settle
850  OUTPUT @Dmm;"MEAS:VOLT:DC?"          ! measure output with Dmm and
860  ENTER @Dmm;Dmm_rdg                  ! store in variable Dmm_rdg
870  PRINT Dmm_rdg
```

3

Chapter 3 Calibration Procedures

Calibration Program

continued

```
880 OUTPUT @Pwrsupply;"CAL:VOLT:DATA ";Dmm_rdg ! send stored value to Power Supply
890 OUTPUT @Pwrsupply;"CAL:VOLT:LEV MID" ! set output to middle cal value
900 WAIT 2 ! allow output to settle
910 OUTPUT @Dmm;"MEAS:VOLT:DC?" ! measure output with Dmm and
920 ENTER @Dmm;Dmm_rdg ! store in variable Dmm_rdg
930 PRINT Dmm_rdg
940 OUTPUT @Pwrsupply;"CAL:VOLT:DATA ";Dmm_rdg ! send stored value to Power Supply
950 OUTPUT @Pwrsupply;"CAL:VOLT:LEV MAX" ! set output to maximum cal value
960 WAIT 2 ! allow output to settle
970 OUTPUT @Dmm;"MEAS:VOLT:DC?" ! measure output with Dmm and
980 ENTER @Dmm;Dmm_rdg ! store in variable Dmm_rdg
990 PRINT Dmm_rdg
1000 OUTPUT @Pwrsupply;"CAL:VOLT:DATA ";Dmm_rdg ! send stored value to Power Supply
1010 OUTPUT @Pwrsupply;"OUTP OFF"
1020 OUTPUT @Pwrsupply;"SYST:ERR?"
1030 ENTER @Pwrsupply;Error$
1040 !
1050 ! Check to see if there is an error. If there is an error,
1060 ! display the error and exit the program.
1070 !
1080 CLEAR SCREEN
1090 IF Error$="+0,""No error"" THEN
1100 PRINT "Voltage calibration completed for Power Supply "
1110 ELSE
1120 PRINT "ERROR: ";Error$;"Voltage not Calibrated"
1130 BEEP
1140 GOTO 2250
1150 END IF
1160 PRINT TABXY(10,5),"VOLTAGE CALIBRATION COMPLETE"
1170 PRINT TABXY(10,7),"BEGIN OVP CALIBRATION"
1180 WAIT 4
1190 CLEAR SCREEN
1200 OUTPUT @Pwrsupply;"OUTP ON" ! Turn on Power Supply output
1210 OUTPUT @Pwrsupply;"CAL:VOLT:PROT" ! Perform OVP circuit calibration
1220 WAIT 9 ! Allow OVP calibration to finish
1230 OUTPUT @Pwrsupply;"OUTP OFF" ! Turn off Power Supply output
1240 OUTPUT @Pwrsupply;"SYST:ERR?"
1250 ENTER @Pwrsupply;Error$
1260 !
1270 ! Check to see if there is an error. If there is an error,
1280 ! display the error and exit the program.
1290 !
1300 CLEAR SCREEN
1310 IF Error$="+0,""No error"" THEN
1320 PRINT "OVP calibration completed for Power Supply "
1330 ELSE
1340 PRINT "ERROR: ";Error$;"OVP not Calibrated"
1350 BEEP
1360 GOTO 2250
1370 END IF
```

Chapter 3 Calibration Procedures Calibration Program

continued

```
1380 CLEAR SCREEN
1390 PRINT TABXY(10,5),"DAC ERROR CORRECTION AND VOLTAGE/OVP CALIBRATION COMPLETE"
1400 WAIT 4
1410 !
1420 ! Perform the Current calibration and OCP calibration. Alert the operator to
1430 ! hook up the connection before calibrating.
1440 !
1450 ! Alert operator to connect lead
1460 PRINT TABXY(10,10),"*****"
1470 PRINT TABXY(10,11)," Connect a CURRENT SHUNT to the Dmm input for measuring"
1480 PRINT TABXY(10,12)," current. Connect the output to the shunt. Observe Polarity!"
1490 PRINT TABXY(10,13),"*****"
1500 PRINT TABXY(10,15),"Press 'C' to Continue, or 'X' to eXit, then 'Enter':"
1510 Ch$="C"
1520 INPUT Ch$
1530 IF Ch$="X" OR Ch$="x" THEN GOTO 2250
1540 OUTPUT @Pwrsupply;"OUTP ON" ! Turn on Power Supply output
1550 CLEAR SCREEN
1560 PRINT TABXY(10,7),"BEGIN CURRENT/OCP CALIBRATION"
1570 WAIT 4
1580 CLEAR SCREEN
1590 OUTPUT @Pwrsupply;"CAL:CURR:LEVel MIN" ! set output to minimum cal value
1600 WAIT 2 ! allow output to settle
1610 OUTPUT @Dmm;"MEAS:VOLT:DC? " ! measure output with Dmm and
1620 ENTER @Dmm;Dmm_rdg ! store in variable Dmm_rdg
1630 Dmm_rdg=Dmm_rdg/Current_shunt ! scale reading to amps
1640 PRINT Dmm_rdg
1650 OUTPUT @Pwrsupply;"CAL:CURR:DATA ";Dmm_rdg ! send stored value to Power Supply
1660 OUTPUT @Pwrsupply;"CAL:CURR:LEVel MID" ! set output to middle cal value
1670 WAIT 2 ! allow output to settle
1680 OUTPUT @Dmm;"MEAS:VOLT:DC? " ! measure output with Dmm and
1690 ENTER @Dmm;Dmm_rdg ! store in variable Dmm_rdg
1700 Dmm_rdg=Dmm_rdg/Current_shunt ! scale reading to amps
1710 PRINT Dmm_rdg
1720 OUTPUT @Pwrsupply;"CAL:CURR:DATA ";Dmm_rdg ! send stored value to Power Supply
1730 OUTPUT @Pwrsupply;"CAL:CURR:LEVel MAX" ! set output to maximum cal value
1740 WAIT 2 ! allow output to settle
1750 OUTPUT @Dmm;"MEAS:VOLT:DC?" ! measure output with Dmm and
1760 ENTER @Dmm;Dmm_rdg ! store in variable Dmm_rdg
1770 Dmm_rdg=Dmm_rdg/Current_shunt ! scale reading to amps
1780 PRINT Dmm_rdg
1790 OUTPUT @Pwrsupply;"CAL:CURR:DATA ";Dmm_rdg ! send stored value to Power Supply
1800 OUTPUT @Pwrsupply;"OUTP OFF" ! Turn off Power Supply output
1810 OUTPUT @Pwrsupply;"SYST:ERR?"
1820 ENTER @Pwrsupply;Error$
1830 !
1840 ! Check to see if there is an error. If there is an error,
1850 ! display the error and exit the program.
```

3

Chapter 3 Calibration Procedures

Calibration Program

continued

```
1860 !
1870 CLEAR SCREEN
1880 IF Error$="+0,""No error"" THEN
1890     PRINT "Current calibration completed for Power Supply "
1900 ELSE
1910     PRINT "ERROR: ";Error$;"Current not Calibrated"
1920     BEEP
1930     GOTO 2250
1940 END IF
1950 CLEAR SCREEN
1960 PRINT TABXY(10,5),"CURRENT CALIBRATION COMPLETE"
1970 PRINT TABXY(10,7),"BEGIN OCP CALIBRATION"
1980 WAIT 4
1990 CLEAR SCREEN
2000 OUTPUT @Pwrsupply;"OUTP ON"                ! Turn on Power Supply output
2010 OUTPUT @Pwrsupply;"CAL:CURR:PROT"          ! Perform OCP calibration
2020 WAIT 9                                     ! Allow OCP calibration to finish
2030 OUTPUT @Pwrsupply;"OUTP OFF"              ! Turn off Power Supply output
2040 OUTPUT @Pwrsupply;"SYST:ERR?"
2050 ENTER @Pwrsupply;Error$
2060 !
2070 ! Check to see if there is an error.  If there is an error,
2080 ! display the error and exit the program.
2090 !
2100 CLEAR SCREEN
2110 IF Error$="+0,""No error"" THEN
2120     PRINT "OCP calibration completed for Power Supply "
2130 ELSE
2140     PRINT "ERROR: ";Error$;"OCP not Calibrated"
2150     BEEP
2160     GOTO 2250
2170 END IF
2180 CLEAR SCREEN
2190 PRINT TABXY(10,5),"CURRENT/OCP CALIBRATION COMPLETE"
2200 !
2210 ! Create a time stamp and output to power supply
2220 !
2230 Cal_msg$="Last Calibrated "&DATE$(TIMEDATE)&" "&TIME$(TIMEDATE)
2240 OUTPUT @Pwrsupply;"CAL:STR """;Cal_msg$;""
2250 OUTPUT @Pwrsupply;"CAL:SEC:STAT ON, ";Sec_code$
2260 OUTPUT @Pwrsupply;"VOLT:PROT:STAT ON"
2270 OUTPUT @Pwrsupply;"CURR:PROT:STAT ON"
2280 DISP "Calibration terminated. "
2290 END
```

End of Program

Theory of Operation

Theory of Operation

This chapter provides block diagram level descriptions of the power supply. The descriptions provide a basic understanding of circuit operation and are intended as an aid in troubleshooting. It is assumed in the following discussions that you are familiar with the operating and programming instructions presented in the E3632A User's Guide. Subjects covered include the following:

- Block Diagram Overview, page 79
- AC Input and Bias Supplies, page 81
- Floating Logic, page 82
- D-to-A Converter, page 84
- A-to-D Converter, page 85
- Power Mesh and Control, page 86
- Earth-Referenced Logic, page 88
- Front Panel, page 88

Block Diagram Overview

This discussion pertains to the block diagram on the next page. The power supply's circuitry is divided into two major blocks: the floating circuitry and the ground referenced circuitry. All power mesh and control circuits, display circuit, and digital circuits are contained in the floating circuitry. This circuitry also contains the power supply's main controller. The earth referenced circuitry provides the interface between the user and the power supply.

The floating circuitry can be viewed in four pieces; the DAC system, the digital logic section (floating logic), the power mesh and control section, and the front panel (display and keyboard) section.

The floating logic receives digital signals from the earth-referenced logic and the DAC converts them to analog signals which are sent to the power control circuits in order to program the power supply's output voltage and current. The power supply can also be commanded to send measurement and status data back to the remote interface controller and/or the VFD (vacuum fluorescent display) display on the front panel. The data is processed and sent back via the floating logic and earth-referenced logic.

The power mesh and control circuits contains voltage and current control circuits which allows the power supply to operate in either the constant voltage (CV) or constant current (CC) mode. The control circuits compare the power supply's output voltage or current with the programmed value and generates a control signal which varies the conduction of the series pass transistor to raise or lower the output as required.

The front panel circuits consist of VFD control, display high voltage drivers, and keyboard scanning. Communication between the front panel and floating logic circuits is accomplished through a 4-wire bi-directional serial interface.

The earth referenced circuitry uses a controller configured as a slave to the main controller. This controller establishes external I/O communication with the main controller through a bi-directional, optically isolated, serial communications link. The earth referenced controller controls low-level GPIB (IEEE-488) and RS-232 interface operation.

Separate reference and bias supplies are provided for the floating and ground reference circuitry. The front panel operates from the floating circuitry with its logic common different from the main controller logic common.

Block Diagram

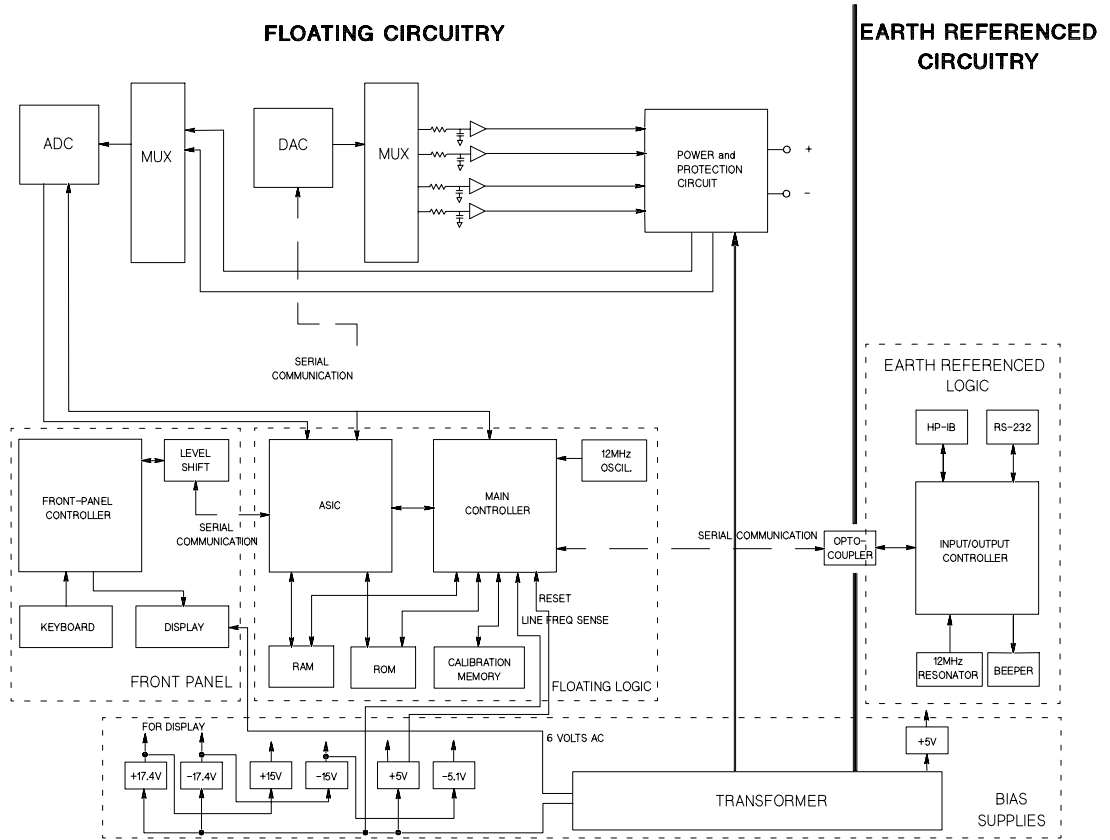

AC Input and Bias Supplies

Referring to the schematic shown on page 121 and 122, the ac mains are connected by a fused power module. This module incorporates the functions of mains connection, fusing, and line voltage selection (100/115/230 Vac). The line voltage selection function of the module selects which primary winding of power transformer is energized. The transformer secondary windings are connected to the main pc board through connectors.

The bias supplies are consists of four sections; +5 Vdc and -5.1 Vdc for the power circuits and floating logic; ± 17.4 Vdc for the display; and +5 Vdc for the earth referenced logic. Power-on reset signals are provided by the +5 Vdc supply of the floating logic.

The ± 17.4 Vdc for the display circuits are produced by rectifier CR4, filter capacitors C19 and C24, and voltage regulators U12 and U16. A separate winding of transformer provides a center tapped 6 Vrms filament supply for the display.

The floating +5 Vdc is produced from the separate winding of transformer. The +5_REF signal is derived from +15 Vdc supply and the TURN_ON RESET signal is derived from +5 Vdc supply. The FAN FAIL signal is asserted when the fan current through R15 is not detected. The TURN_ON RESET signal holds the main controller and other logic in a reset state until the +5 Vdc logic power is fully operational. This signal is generally active only following application of line power to the instrument.

The +5V dc earth referenced supply is produced by rectifier CR7, filter capacitor C21, and regulator U10. The GPIB (IEEE-488) and RS-232 computer interfaces are powered from this supply.

Floating Logic

Referring to the schematic shown on page 124, the floating common logic controls operation of the entire instrument. All output functions and bus command interpretation is performed in the main controller U17. The front panel and the earth referenced logic operate as slaves to U17. The floating common logic is comprised of the main controller U17, custom gate array U16, the program ROM U13, RAM U14, calibration EEPROM U15, and the 12 MHz clock oscillator. Non-volatile EEPROM U15 stores calibration constants, calibration secure code, and calibration count, and store/recall variables. Power-on reset is provided to the main controller by the voltage regulator U11. The main controller U17 is a 16-bit micro controller. It controls such features as receive and transmit serial port, timer/counter ports, an 8-bit pulse width modulated DAC port, and selectable input 10-bit successive approximation a-to-d convert ports. A conventional address/data bus is used to transfer data between the main controller and external ROM and RAM. When the address latch enable (ALE) signal goes high, address data is present on the address/data bus. ASIC U18 latches the address data and decodes the correct chip enable (low true) for external ROM and RAM accesses and for read/write accesses to the internal registers of U18. The system memory map is shown below.

0000 _H - 1FF7 _H	U15	32k x 8	RAM
1FF8 _H - 1FFF _H	U16		Gate Array
2000 _H - FFFF _H	U14		Program ROM

Program ROM U13 contains four 64k x 8 data banks of data. Banks are selected by controlling A16 and A17 ROM address bits directly from the main controller port bits.

Custom gate array U18 performs address latching and memory map decoding functions as discussed above. In addition, U18 contains a variety of internal read/write registers. The read (XRD) and write (XWR) signals transfer data out of and into U18 when it is addressed. There are four internal registers in U18: an internal configuration register, an 8 bit counter register, a serial transmit/receive register, and an internal status register.

The counter register is used to capture the ADC slope count at the COMP input. The COMP input functions as both a clocked comparator and the slope counter input for the ADC. In both cases the counter register captures the lower 8 bits of a 24-bit counter. The upper 16 bits of the count are captured by the SYNC input to U17.

The serial register is used to send and receive serial data bytes from the main controller to the DAC system, or to communicate with the front panel controller. The serial register is multiplexed to these two circuits. The transmission rate is selected to 1.5 M bits/second for the DAC system and 93.75 k bits/second for communication with the front panel controller. The general serial interface is a 3-bit interface as shown below.

U18 Internal Signal	Configuration Signals	Front Panel Signals
Serial Clock	SERCK	XFPSK
Data OUT (send)	SERDAT	FPDI
Data IN (receive)	SERRBK	FPDO

Serial data is received simultaneously as serial data is clocked out. Front panel data is exchanged in both directions whenever a byte is sent from U18. The input data of DAC is strobed to outputs by U17 signal SERSTB. Interrupts from the front panel are detected by U18 and signaled to the CHINT. The main controller FPINT signals the front panel controller that U18 has data to send.

The power supply's calibration data are stored in a 256 x 16 bit non-volatile electrically erasable ROM U15. This non-volatile ROM read/write data is accessed by a 4-bit serial protocol controlled by U17.

The main controller has an on-chip 10-bit successive approximation ADC. The FLASH input is used to sample the residual charge on the main integrating ADC output of U26.

Port bits are also configured to measure the input power line frequency (LSENSE). Frequencies from 55 Hz to 66 Hz are measured as 60 Hz. All other line input frequencies are assumed to be 50 Hz.

The main controller communicates with the earth referenced controller U4 through an optically isolated (U6 and U7) asynchronous serial link. Data is sent in an 11-bit frame at a rate of 187.5 k bits/ second. When the RS-232 interface is selected, data is sent across the isolated link at 93.75 k bits/second. The 11-bit data frame is configured for one start bit, eight data bits, one control bit, and one stop bit.



D-to-A Converter

Referring to the schematic shown on page 123, all reference voltages of power circuits are derived from the internal voltage reference of system DAC U21. The system DAC track/hold amplifier outputs are used to provide controllable reference voltages to three power circuits. The system DAC is programmed and responds to the main controller via internal 3-wire serial data bus SERCLK, SERRBK, and SERSTB. The system DAC is multiplexed to 6 track/hold amplifiers through U27. Each track/hold amplifier is refreshed approximately every 1 msec to maintain its output setting. Changes to track/hold amplifier outputs are accomplished by dwelling on that position for an extended period.

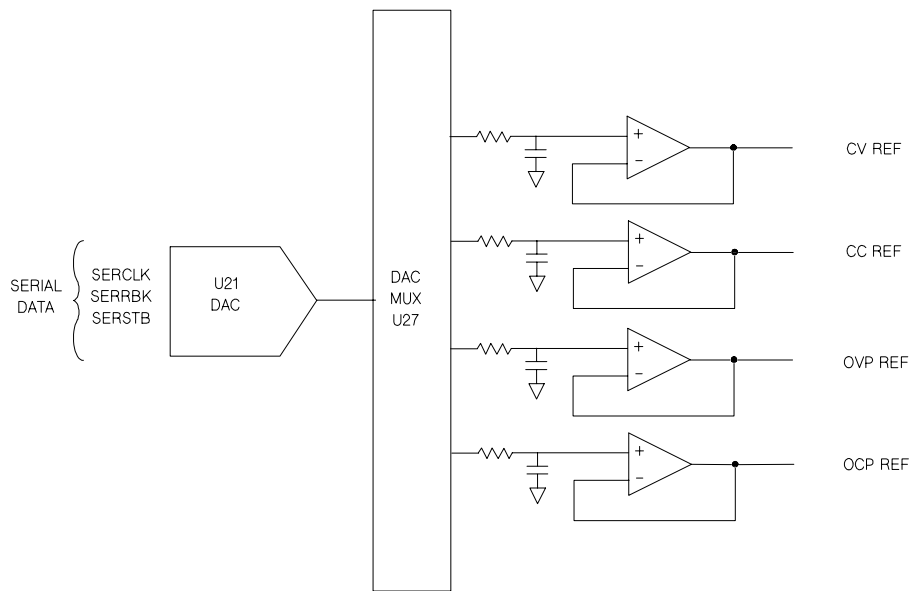

A-to-D Converter

Referring to the schematic shown on page 123, the analog-to-digital converter (ADC) is used to change dc voltages into digital information. The circuitry consists of an integrator amplifier (U26 and U29), current steering switch U33, resistors (R70, R71, and R96), voltage reference U32, ADC controller U18, and residue ADC U17.

The ADC method used by the Agilent E3632A is called *multislope III*. Multislope III is a charge balancing continuously integrating analog-to-digital converter. The input voltage continuously forces charge onto the integrator capacitors C49 and C51 through R71.

Switch U33 steers fixed positive or negative reference currents onto the integrator capacitors to cancel, or balance the accumulated input charge. The level shifted (R97 and R98) output of the integrator is checked every 2.66 μ sec by the U18 COMP input. Logic state machines in U18 control the U33 current steering to continuously seek an approximate 2.5 V level on the integrator amplifier output, FLASH. If the ADC input voltage is between ± 15 V, the integrator output (FLASH) will remain within the 0 V to 5 V range of the U17 on-chip ADC. The U17 ADC input (FLASH) is clamped to 0 V or 5 V by R53 and CR16 to protect U17.

The integrator amplifier is formed by U26 and U29. Resistors R61 and R62 affect the amplifier stability. Amplifier oscillation may occur if their values are incorrect. Amplifier U29 improves the offset voltage characteristics of integrator amplifier U26.

Each analog-to-digital conversion occurs continuously. The ADC starts by clearing the integrator slope count in U18. At the end of the integration period, the slope count is latched. The slope count provides the most significant bits of the input voltage conversion. The least significant bits are converted by the on-chip ADC of U17.

U39 provides a stable +5 V reference voltage for ADC. U32A amplifies the voltage reference to +10 V while amplifier U32B inverts the +10 V reference to -10 V. The reference voltage forces precision slope currents for the integrating ADC through R70 and R96.

Power Mesh and Control

Refer to the schematics shown on page 121.

For the power mesh and control circuit, a preregulator is added ahead of the series pass transistor to minimize the power dissipated in the series pass transistor by controlling the dc level across the input filter capacitor, depending on the output voltage.

To achieve this, tap switching is accomplished by a SCR and one bridge diode and the SCR control circuit in each power circuit; CR14, CR17, CR18, CR19, and CR11. By turning on or off the SCR, these circuits allow the input capacitors (C36, C65, and C46) to charge to one of two discrete voltage levels, depending on the output voltage required. When the SCR is not fired, the bridge diode conducts and the low voltage of two discrete voltage levels is developed across the input filter capacitors.

The SCR control circuit determines whether SCR is to be fired by monitoring the output voltage and comparing this value against internally derived reference levels.

The series pass transistor is part of a feedback loop which consists of the driver and the Constant Voltage/Constant Current error amplifier. The feedback loop provides "fine and fast" regulation of the output while the preregulator feedback loop handles large, relatively slow, regulation demands.

The series pass transistor is made to alter its conduction to maintain a constant output voltage or current. The voltage developed across the current sampling resistors is the input to the constant current error amplifier. The constant voltage error amplifier obtains its input from differential amplifier which senses the output voltage. Any changes in output voltage or current are detected and amplified by the constant voltage or constant current error circuit and applied to the series pass transistor in the correct phase and amplitude to counteract the change in output voltage or current.

Two error amplifiers are included in a CV/CC supply, one for controlling output voltage, the other for controlling output current. Since the constant voltage amplifier tends to achieve zero output impedance and alters the output current whenever the load resistance changes, while the constant current amplifier causes the output impedance to be infinite and changes the output voltage in response to any load resistance change, it is obvious that the two amplifiers can not operate simultaneously. For any given value of load resistance, the power supply must act either as a constant voltage source or as a constant current source - it can not be both; transfer between these two modes is accomplished at a value of load resistance equal to the ratio of the output voltage control setting to the output current control setting.

Full protection against any overload condition is inherent in the Constant Voltage/Constant Current design principle since there is not any load condition that can cause an output which lies outside the operating region. For either constant voltage or constant current operation, the proper choice of front panel voltage and current limit settings insures optimum protection for the load device as well as full protection for the power supply.

The diodes connected across the output terminals in reverse polarity protect the output electrolytic capacitor and the series pass transistors from the effects of a reverse voltage applied across the output terminals.

Earth-Referenced Logic

Referring to the schematic shown on page 125, the earth referenced logic circuits schematic provides all rear panel input/output capability. Microprocessor U4 handles GPIB (IEEE-488) control through bus interface chip U3 and bus receiver/driver chips U1 and U2. The RS-232 interface is also controlled through microprocessor U4. RS-232 transceiver chip U17 provides the required level shifting to approximate ± 9 volt logic levels through on-chip charge-pump power supplies using C5 and C15. Communication between the earth referenced logic interface circuits and the floating logic is accomplished through an optically-isolated bi-directional serial interface. Isolator U7 couples data from U4 to processor U17. Isolator U6 couples data from U17 to microprocessor U4.

Front Panel

Referring to the schematic shown on page 127, the front panel circuits consist of vacuum fluorescent display control, display high voltage drivers, and keyboard scanning. Communication between the front panel and floating logic circuits is accomplished through a 4-wire bi-directional serial interface. The main controller U17 can cause a hardware reset to front-panel controller by signal IGFPRES. The front panel logic operates from -12.4 volts (logic 1) and -17.4 volts (logic 0). The front panel logic high supply (-12.4 volts) is produced by the -17.4 volts bias supply and the voltage regulator U2 on the front panel board. The four serial communication signals are level shifted by the comparator U8 from the floating logic 0 V to 5 V levels to the -17.4 V to -12.4 V levels present on the front panel assembly. U6 acts as the serial shift register interface for the front-panel controller U7 on the front panel board.

Display anode and grid voltages are +17.4 volts for an "on" segment and -17.4 volts for an "off" segment. The -11.2 V cathode bias for the display is provided by filament winding center tap bias circuit VR1, R18, and C25 on the main board. Keyboard scanning is accomplished through a conventional scanned row-column key matrix. Keys are scanned by outputting data at front-panel controller U7 port pins P0.0 through P0.3 to poll each key column for a key press. Column read-back data are read by the microprocessor at port pins P1.0 through P1.3 for decoding and communication to the floating logic circuits.

Service

Service

This chapter discusses the procedures involved for returning a failed power supply to Agilent Technologies for service or repair. Subjects covered include the following:

- Operating Checklist, page 91
- Types of Service Available, page 92
- Repacking for Shipment, page 93
- Electrostatic Discharge (ESD) Precautions, page 94
- Surface Mount Repair, page 94
- To Replace the Power-Line Fuse, page 94
- To Disconnect the Output Using an External Relay, page 95
- Troubleshooting Hints, page 96
- Self-Test Procedures, page 98

Operating Checklist

Before returning your power supply to Agilent Technologies for service or repair check the following items:

Is the Power Supply Inoperative?

- Verify that the ac power cord is connected to the power supply.
- Verify that the front-panel power switch is depressed.
- Verify that the power-line fuse is installed:
Use the 4 AT, 250 V fuse for 100 or 115 Vac operation.
Use the 2.5 AT, 250 V fuse for 230 Vac operation.
- Verify the power-line voltage setting.
See "To prepare the power supply for use" on page 23.

Does the Power Supply Fail Self-Test?

- Verify that the correct power-line voltage is selected.
See "To prepare the power supply for use" on page 23.
- Remove all load connections to the power supply.
Ensure that all terminal connections are removed while the self-test is performed.

Types of Service Available

If your power supply fails within three years of original purchase, Agilent Technologies will repair or replace it free of charge. If your unit fails after your three year warranty expires, Agilent will repair or replace it as a very competitive price. Agilent will make the decision locally whether to repair or replace your unit.

Standard Repair Service (worldwide)

Contact your nearest Agilent Technologies Service Center. They will arrange to have your power supply repaired or replaced.

Express Exchange (U.S.A. only)

You can receive a replacement Agilent E3632A via overnight shipment for low downtime.

1 Call 1-800-258-5165 and ask for "Express Exchange."

- You will be asked for your shipping address and a credit card number to guarantee return of your failed power supply.
- If you do not return your failed power supply within 45 days, your credit card will be billed for a new Agilent E3632A.
- If you choose not to supply a credit card number, you will be asked to send your failed unit to a designated Agilent Service Center. After the failed unit is received, Agilent will send your replacement unit.

2 Agilent will immediately send a replacement Agilent E3632A to you via overnight shipment.

- The replacement unit will have a different serial number than your failed unit.
- If you can not accept a new serial number for the replacement unit, use the *Standard Repair Service* option described above.

- If your failed unit was "in-warranty," your replacement unit continues the original three year warranty period. You *will not* be billed for the replacement unit as long as the failed unit is received by Agilent.
- If your three year warranty has expired, Agilent Technologies will bill you for the Agilent E3632A exchange price - less than a new unit price. Agilent warrants exchange units against defects for 90 days.

Repacking for Shipment

For the Express Exchange Service described on the previous page, return your failed Agilent E3632A to the designated Agilent Service Center using the shipping carton of the exchange unit. A shipping label will be supplied. Agilent will notify you when your failed unit has been received.

If the instrument is to be shipped to Agilent for service or repair, be sure to:

- Attach a tag to the power supply identifying the owner and indicating the required service or repair. Include the instrument model number and full serial number.
- Place the power supply in its original container with appropriate packaging material.
- Secure the container with strong tape or metal bands.

If the original shipping container is not available, place your unit in a container which will ensure at least 4 inches of compressible packaging material around all sides for the power supply. Use static-free packaging materials to avoid additional damage to your unit.

Agilent Technologies recommends that you always insure shipments.

Electrostatic Discharge (ESD) Precautions

Almost all electrical components can be damaged by electrostatic discharge (ESD) during handling. Component damage can occur at electrostatic discharge voltages as low as 50 volts.

The following guidelines will help prevent ESD damage when serving the power supply or any electronic device.

- Disassemble instruments *only* in a static-free work area.
- Use a conductive work area to dissipate static charge.
- Use a conductive wrist strap to dissipate static charge accumulation.
- Minimize handling.
- Keep replacement parts in original static-free packaging.
- Remove all plastic, styrofoam, vinyl, paper, and other static-generating materials from the immediate work area.
- Use *only* anti-static solder suckers.

Surface Mount Repair

Surface mount components should *only* be removed using soldering irons or desoldering stations *expressly* designed for surface mount components. *Use of conventional solder removal equipment will almost always result in permanent damage to the printed circuit board and will void your Agilent Technologies factory warranty.*

To Replace the Power-Line Fuse

The power-line fuse is located within the power supply's fuse-holder assembly on the rear panel (see on page 24). For 100 or 115 Vac operation, you must use a 4 AT slow-blow fuse (Agilent part number 2110-0996). For 230 Vac operation, you must use a 2.5 AT slow-blow fuse (Agilent part number 2110-0999).

To Disconnect the Output Using an External Relay

When the output of the E3632A is turned off, it is implemented by setting the output to 0 volts and 0.02 amps. This gives a zero output voltage without actually disconnecting the output. To disconnect the output, an external relay must be connected between the output and the load. A TTL signal of either low true or high true is provided to control an external relay. This signal can only be controlled with the remote command `OUTPut:RELAy {OFF|ON}`. The TTL output is available on the RS-232 connector pin 1 and pin 9.

When the `OUTPut:RELAy` state is "ON", the TTL output of pin 1 is high (4.5 V) and pin 9 is low (0.5 V). The levels are reversed when the `OUTPut:RELAy` state is "OFF".

Note

TTL output of pin 1 or pin 9 of the RS-232 connector is available only after installing two jumpers inside the power supply. See below for more information.

Note

Do not use the RS-232 interface if you have configured the power supply to output relay control signals. Internal components on the RS-232 circuitry may be damaged.

Installation Procedure

The assembly drawings and schematics are located in chapter 8, "Schematics".

- 1 Remove the front and rear bumpers and take off the cover (See the mechanical disassembly drawing on page 119).
- 2 Install JP3 and JP4 located adjacent to the connector P5 (The JP3 and JP4 are outlined with a circle in the component locator diagram on page 120). A bare wire may be used.
- 3 Reassemble the power supply.

Troubleshooting Hints

This section provides a brief check list of common failures. Before troubleshooting or repairing the power supply, make sure that the failure is in the instrument rather than any external connections. Also make sure that the instrument is accurately calibrated. The power supply's circuits allow troubleshooting and repair with basic equipment such as a digit multimeter and a 100 MHz oscilloscope.

Caution

This instrument contains CMOS integrated circuits which are susceptible to failure due to electrostatic discharge. Refer to the "Electrostatic Discharge (ESD) Precautions" section earlier in this chapter for further handling precautions.

Unit is Inoperative

- Verify that the ac power cord is connected to the power supply.
- Verify that the front-panel power switch is depressed.
- Verify that the power-line fuse is installed:
 - Use the 4 AT, 250 V fuse for 100 or 115 Vac operation..*
 - Use the 2.5 AT, 250 V fuse for 230 Vac operation..*
- Verify the power-line voltage setting.
 - See "To prepare the power supply for use" on page 23.*

Unit Reports Errors 740 to 750

These errors may be produced if you accidentally turn off power the unit during a calibration or while changing a non-volatile state of the instrument. Recalibration or resetting the state should clear the error. If the error persists, a hardware failure may have occurred.

Unit Fails Self-Test

Verify that the correct power-line voltage setting is selected. Also, ensure that all terminal connections are removed while the self-test is performed. Failure of the DAC U21 on the top board will cause many self-test failures.

Bias Supplies Problems

Check that the input to the voltage regulators of the bias supplies is at least 1 V greater than their output.

Circuit failures can cause heavy loads of the bias supplies which may pull down the regulator output voltages.

Check the voltages of bias supplies as tabulated below.

Table 5-1. Bias Supplies Voltages

Bias Supply	Minimum	Maximum	Check At
+5V Floating	+4.75 V	+5.25 V	U11 pin 2
-5.1V Floating	-4.75 V	-5.25 V	Anode of CR5
+15V Floating	+14.25 V	+15.75 V	Anode of CR9
-15V Floating	-14.25 V	-15.75 V	Cathode of CR10

Some circuits produce their own local bias supplies from the main bias supplies. Be sure to check that these local bias supplies are active. In particular, the ADC (analog-to-digital converter), ac input, and front panel sections have local bias supplies. Always check that the power supplies are free of ac oscillations using an oscilloscope. Failure of bias supplies will cause many self-test failures.

Self-Test Procedures

Power-On Self-Test

Each time the power supply is powered on, a set of self-tests are performed. These tests check that the minimum set of logic and measurement hardware are functioning properly. The power-on self-test performs checks 601 through 604 and 624 through 634.

Complete Self-Test

Hold any front panel key except the "Error" key for more than 5 seconds while turning on the power to perform a complete self-test. The power supply beeps when the test starts. The tests are performed in the order shown below.

- 601 Front Panel Does not respond** The main controller U17 on the top board attempts to establish serial communications with the front panel controller U7 on the front panel board. During this test, U7 turns on all display segments. Communication must function in both directions for this test to pass. If this error is detected during power-on self-test, the power supply will beep twice. This error is only readable from the remote interface.
- 602 RAM read/write failed** This test writes and reads a 55_h and AA_h checker board pattern to each address of ram U14. Any incorrect readback will cause a test failure. This error is only readable from the remote interface.
- 603 A/D sync stuck** The main controller issues an A/D sync pulse to U17 and U18 to latch the value in the ADC slope counters. A failure is detected when a sync interrupt is not recognized and subsequent time-out occurs.
- 604 A/D slope convergence failed** The input amplifier is configured to the measure zero (MZ) state in the 10 V range. This test checks whether the ADC integrator produces nominally the same number of positive and negative slope decisions ($\pm 10\%$) during a 20 ms interval.
- 605 Cannot calibrate rundown gain** This test checks the nominal gain between integrating ADC and the U17 on-chip ADC. This error is reported if the procedure can not run to completion due to a hardware failure.

- 606 **Rundown gain out of range** This test checks the nominal gain between the integrating ADC and the U17 on-chip ADC. The nominal gain is checked to $\pm 10\%$ tolerance.
- 607 **Rundown too noisy** This test checks the gain repeatability between the integrating ADC and the U17 on-chip ADC. The gain test (606) is performed eight times. Gain noise must be less than ± 64 lsb's of the U17 on-chip ADC.
- 608 **Serial configuration readback failed** This test re-sends the last 3 byte serial configuration data to all the serial path (SERDAT, SERBCK, SERCLK). The data is then clocked back into U18 on the top board and compared against the original 3 bytes sent. A failure occurs if the data do not match. This tests checks the serial data path through U22.
- 624 **Unable to sense line frequency** This test checks that the LSENCE logic input U17 is toggling. If no logic input detected, the power supply will assume a 50 Hz line operation for all future measurements.
- 625 **I/O processor did not respond** This test checks that communications can be established between U17 and U4 through the optically isolated (U6 and U7) serial data link. Failure to establish communication in either direction will generate an error. If this condition is detected at power-on self-test, the power supply will beep and the error annunciator will be on.
- 626 **I/O processor failed self-test** This test causes the earth referenced processor U4 to execute an internal, ram test. Failure will generate an error.
- 630 **Fan test failed** This test checks if the fan current is flowing. If the current is not detected at power-on self-test, the power supply will beep and the error annunciator will be on. Fan test fail could likely induce overtemperature condition in the power supply.
- 631 **System DAC test failed** This test checks if the DAC hardware is functional. The main controller U17 sends a reference voltage data to DAC and converts the DAC output to digital data to see if the digital data is within a valid range.
- 632 **Hardware test failed** This test checks the the status of voltage and current error amplifiers for the power circuit. If both amplifiers are not operational, the power supply will beep and the error annunciator will be on.

Replaceable Parts

Replaceable Parts

This chapter contains information ordering replacement parts for your power supply. The parts lists are divided into the following four groups:

- E3632-60002 Main PC Assembly *page 103*
- E3632-60004 Front-Panel Display PC Assembly *page 111*
- E3632-60005 Front Frame Assembly *page 112*
- Agilent E3632A Power Supply Assembly *page 112*

Parts are listed in the alphanumeric order according to their schematic reference designators. The part lists include a brief description of the part with applicable Agilent part numbers and manufacturer part number.

To Order Replaceable Parts

You can order replaceable parts from Agilent using the Agilent part number or directly from the manufacturer using the manufacturer's part number. Note that not all parts listed in this chapter are available as field-replaceable parts. To order replaceable parts from Agilent, do the following.:

- 1 Contact your nearest Agilent Sales Office or Agilent Service Center.
- 2 Identify the parts by their Agilent part number shown in the replaceable parts list.
- 3 Provide the instrument model number and serial number.

Backdating and Part Changes

Always refer to chapter 7, "Backdating" before attempting repair or before ordering replacement parts. Parts changes are documented in the backdating chapter.

E3632-60002 Main PC Assembly

Printing History
Edition 2, April 2000

New editions are complete revisions of the manual. Update packages, which are issued between editions, may contain additional information and replacement pages which you merge into the manual. The dates on this page change only when a new edition is published.

Trademark Information
Windows, Windows 95, and Windows NT are registered trademarks of Microsoft Corp.

Certification
Agilent Technologies certifies that this product met its published specifications at the time of shipment. Agilent further certifies that its calibration measurements are traceable to the United States National Institute of Standards and Technology (formerly National Bureau of Standards), to the extent allowed by that organization's calibration facility, and to the calibration facilities of other International Standards Organization members.

Warranty
This Agilent product is warranted against defects in materials and workmanship for a period of three years from date of shipment. Duration and conditions of warranty for this product may be superseded when the product is integrated into (becomes a part of) other Agilent products. During the warranty period, Agilent will, at its option, either repair or replace products which prove to be defective. The warranty period begins on the date of delivery or on the date of installation if installed by Agilent.

Warranty Service
For warranty service or repair, this product must be returned to a service facility designated by Agilent.

For products returned to Agilent for warranty service, the Buyer shall prepay shipping charges to Agilent and Agilent shall pay shipping charges to return the product to the Buyer. However, the Buyer shall pay all shipping charges, duties, and taxes for products returned to Agilent from another country.

Limitation of Warranty
The foregoing warranty shall not apply to defects resulting from improper or inadequate maintenance by the Buyer, Buyer-supplied products or interfacing, unauthorized modification or misuse, operation outside of the environmental specifications for the product, or improper site preparation or maintenance.

The design and implementation of any circuit on this product is the sole responsibility of the Buyer. Agilent does not warrant the Buyer's circuitry or malfunctions of Agilent products that result from the Buyer's circuitry. In addition, Agilent does not warrant any damage that occurs as a result of the Buyer's circuit or any defects that result from Buyer-supplied products.

To the extent allowed by local law, Agilent makes no other warranty, expressed or implied, whether written or oral with respect to this product and specifically disclaims any implied warranty or condition of merchantability, fitness for a particular purpose or satisfactory quality.

For transactions in Australia and New Zealand: The warranty terms contained in this statement, except to the extent lawfully permitted, do not exclude, restrict, or modify and are in addition to the mandatory statutory rights applicable to the sale of this product.

Exclusive Remedies
To the extent allowed by local law, the remedies provided herein are the Buyer's sole and exclusive remedies. Agilent shall not be liable for any direct, indirect, special, incidental, or consequential damages (including lost profit or data), whether based on warranty, contract, tort, or any other legal theory.

Notice
The information contained in this document is subject to change without notice.

To the extent allowed by local law, Agilent makes no warranty of any kind with regard to this material, including, but not limited to, the implied warranties of merchantability and fitness for a particular purpose.

To the extent allowed by local law, Agilent shall not be liable for errors contained herein or for incidental or consequential damages in connection with the furnishing, performance, or use of this material. No part of this document may be photocopied, reproduced, or translated to another language without the prior written consent of Agilent.

Restricted Rights
The Software and Documentation have been developed entirely at private expense. They are delivered and licensed as "commercial computer software" as defined in DFARS 252.227-7013 (Oct 1988), DFARS 252.211-7015 (May 1991), or DFARS 252.227-7014 (Jun 1995), as a "commercial item" as defined in FAR 2.101(a), or as "restricted computer software" as defined in FAR 52.227-19 (Jun 1987) (or any equivalent agency regulation or contract clause), whichever is applicable. You have only those rights provided for such Software and Documentation by the applicable FAR or DFARS clause or the Agilent standard software agreement for the product involved.

Safety Information
Do not install substitute parts or perform any unauthorized modification to the product. Return the product to an HP Sales and Service Office for service and repair to ensure that safety features are maintained.

Safety Symbols
Warning
Calls attention to a procedure, practice, or condition, that could possibly cause bodily injury or death.

Caution
Calls attention to a procedure, practice, or condition that could possibly cause damage to equipment or permanent loss of data.



Earth ground symbol.



Chassis ground symbol.



Refer to the manual for specific Warning or Caution information to avoid personal injury or equipment damage. Hazardous voltages may be present.

Warning
No operator serviceable parts inside. Refer servicing to service-trained personnel.

Warning
For continued protection against fire, replace the line fuse only with a fuse of the specified type and rating.